

SIEMENS

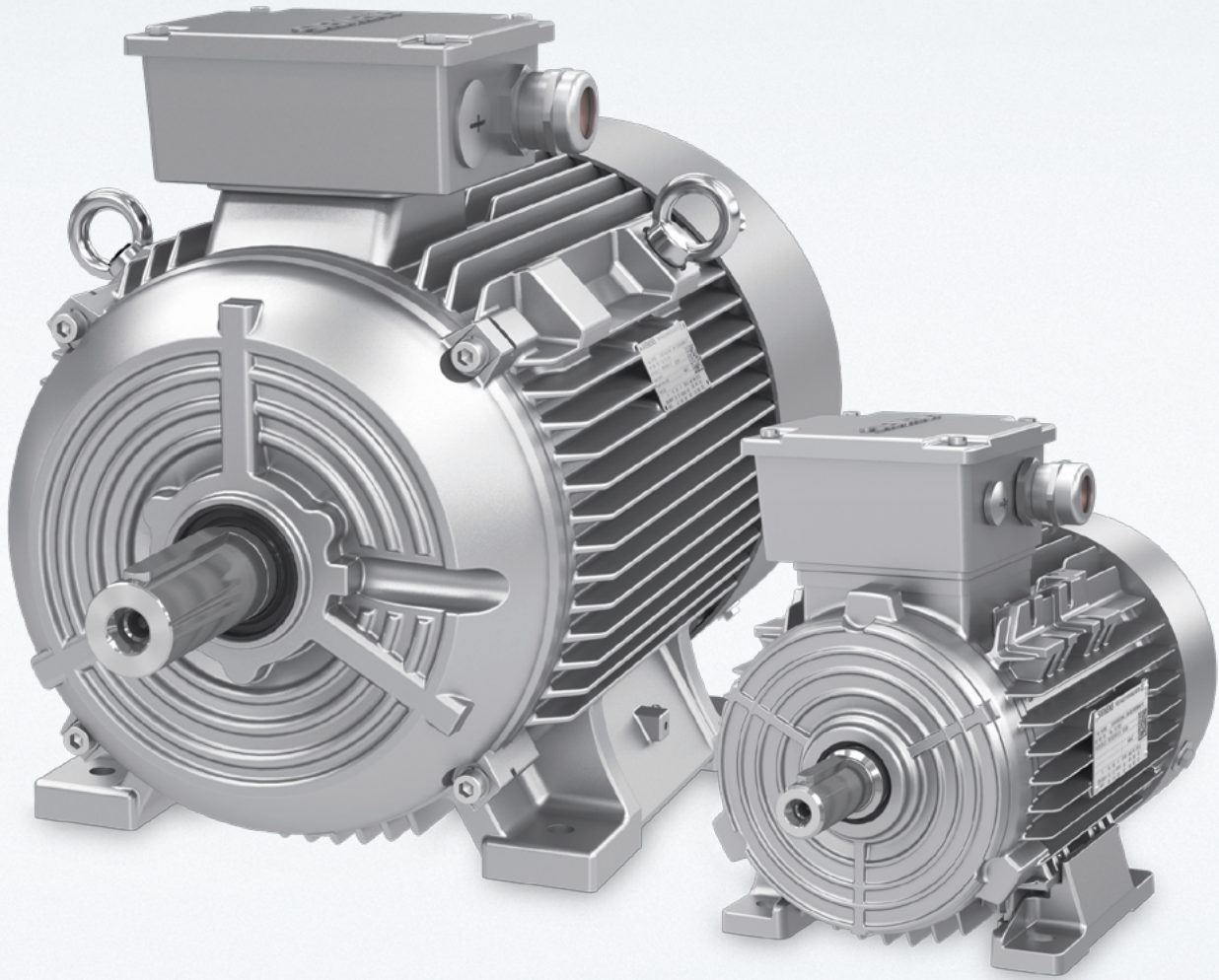

SIMOTICS Motors

SIMOTICS FL Low-Voltage Motors

Type series 1LE0323 and 1LE0043

Frame sizes 80 to 225 · Power range 0.55 to 45 kW

Catalog
D 81.6

Edition
12/2022

[siemens.com/drives](https://www.siemens.com/drives)

Related catalogs

SIMOTICS GP, SD, XP, DP Low-Voltage Motors

D 81.1

Type series 1FP1, 1LE1, 1LE5, 1MB1, 1MB5, 1PC1
Frame sizes 63 to 450
Power range 0.09 to 1000 kW
PDF (E86060-K5581-A111-B4-7600)



Motion Control Drives

D 31.1

SINAMICS Inverters for Single-Axis Drives
Built-In Units

E86060-K5531-A111-A1-7600



Motion Control Drives

D 31.2

SINAMICS Inverters for Single-Axis Drives
Distributed Inverters

E86060-K5531-A121-A1-7600



SINAMICS G130

Drive Converter Chassis Units

SINAMICS G150

Drive Converter Cabinet Units

D 11

E86060-K5511-A101-A6-7600



SINAMICS S120

Chassis Format Converter Units
Chassis-2 Format Converter Units
Cabinet Modules, Cabinet Modules-2

SINAMICS S150

Converter Cabinet Units
E86060-K5521-A131-A7-7600

D 21.3



All catalogs and other information material, such as brochures, manuals and operating instructions for standard drive systems are available up-to-date on the Internet at the following address:

www.siemens.com/drives/catalogs

The listed documentation can be ordered here or it is available in commonly used file formats (PDF, ZIP) for downloading.

SinaSave energy saving/energy efficiency tool

Further information on the subject of energy saving and the SinaSave energy efficiency tool is available at the following address:

www.sinasave.siemens.com

SIMOTICS FL Low-Voltage Motors

Type series 1LE0323 and 1LE0043

Motors

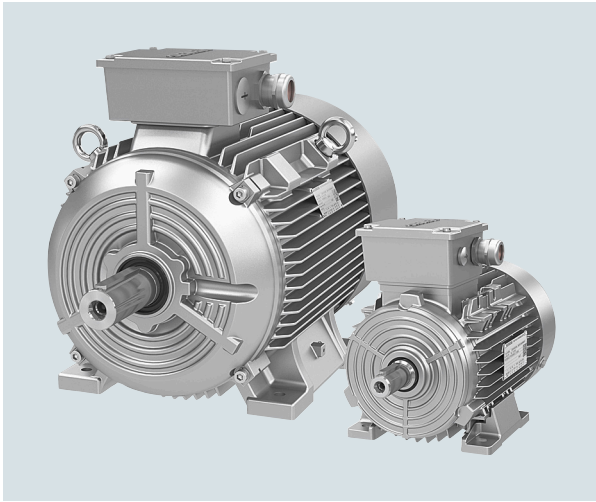

[Catalog D 81.6 · 12/2022](#)

This catalog is only applicable in designated countries for the following regions:

- Africa
- Europe
- Middle East

Please contact your local Siemens branch.

© Siemens AG 2020

Introduction
SIMOTICS motors
Technical features

1

SIMOTICS FL standard motors
Orientation
Flow Line · IE3 Premium Efficiency
Article No. supplements and special versions
Dimensions

2



The products and systems described in this catalog are manufactured/distributed under application of a certified quality management system in accordance with DIN EN ISO 9001 (04-31-1267 Certified Registration No. CN00118Q37058R5L/3200). The certificate is recognized by all IQNet countries.

Introduction



1/2	SIMOTICS motors
1/2	General information
1/7	Technical features
1/7	Versions in accordance with standards and specifications
1/8	Voltage and frequency
1/8	Tolerance for electrical data
1/9	Efficiency classes and efficiencies according to IEC 60034-30-1
1/11	Types of construction
1/11	IP rating
1/13	Windings and insulation
1/14	Rating plates
1/15	Coolant temperature and installation altitude
1/17	Motor protection
1/18	Converter operation
1/20	Noise levels
1/20	Bearings and lubrication
1/24	Terminal boxes
1/24	Packaging
1/25	Lifting eyes and transport
1/25	Certificates
1/26	Efficiency, power factor, rated speed, direction of rotation, rated torque

Introduction

SIMOTICS motors

General information

1

Overview

SIMOTICS – The name for the widest range of motors in the world

With 150 years of experience, we have driven motor technology forward, optimized them and played a decisive role in defining them.

Based on over 150 years of experience Siemens offers with SIMOTICS the most comprehensive range of motors for industrial applications proven with more than 40 million Siemens motors and drives installed around the world.

Our low-voltage motors meet the latest efficiency standards and stand for highest quality, reliability and compactness. Our motors are optimally integrated into the drive train. They are perfectly harmonized for the use with SIRIUS motor starters and SINAMICS frequency converters.

Our foundation of outstanding quality is the unparalleled experience from numerous Siemens production facilities around the world and close to our customers. This is how our experience drives your success!

Siemens is present in more than 190 countries around the world and a true local global player. We manufacture locally serving the individual markets. All of our products are based on one common global quality and design standard derived from our German engineering roots adapted to global market requirements.

We are present in your local market, understand your market's needs and also comply with local requirements and standards.

Let us show you how our experience and our partnership will drive your success with a new motors series specifically defined for the distribution business.

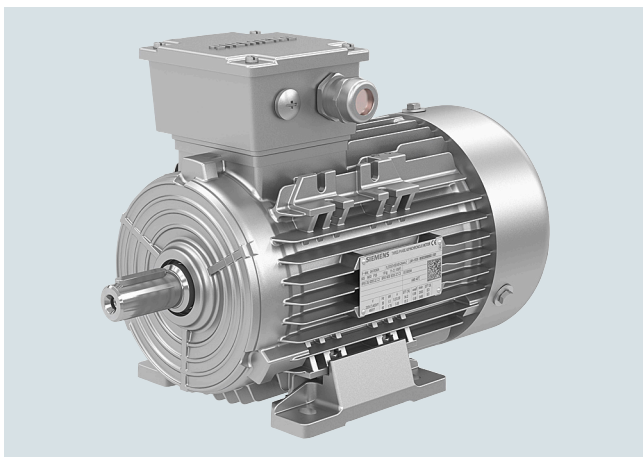

SIMOTICS 1LE0 with aluminum housing, frame size 90

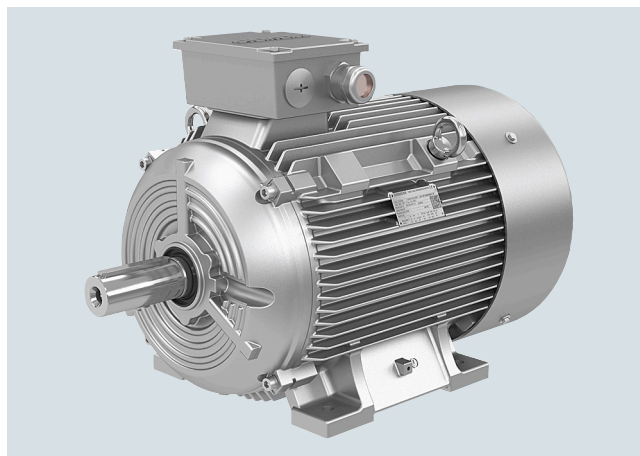

SIMOTICS 1LE0 with cast-iron housing, frame size 180

Overview

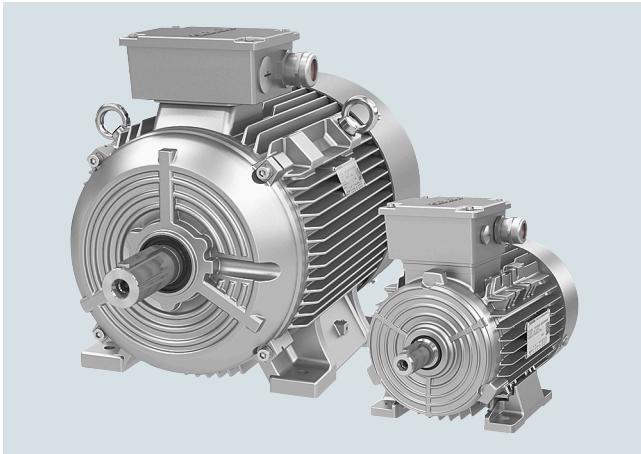

SIMOTICS FL 1LE0 low-voltage motors

This catalog is using all of our 150 years experience and focuses on our SIMOTICS low-voltage IEC motors, especially defined for the distribution market and OEMs. It covers aluminum and cast-iron motor series.

Additional offering is always available from our standard motor catalog portfolio. For further information, please refer to Catalog D 81.1. The SIMOTICS low voltage motors portfolio is covering efficiency classes from IE1 to IE4. This catalog describes only IE3 solutions, which is according to the range of SIMOTICS FL series.

In addition to these general IE1, IE2 and IE3 solutions, Siemens can also provide specific variants for specific markets i.e. in India, China etc. In such instances please consult your local Siemens representative.

Brief overview	Aluminum motors 1LE0323
Power and voltage range:	0.55 ... 18,5 kW
Frame sizes	80 ... 160
Rated speed:	1000 ... 3000 rpm
Number of poles:	2, 4, 6
Efficiency classes:	• IE3 (Premium Efficiency)

Brief overview	Cast-iron motors 1LE0043
Power and voltage range:	15 ... 45 kW
Frame sizes	180 ... 225
Rated speed:	1000 ... 3000 rpm
Number of poles:	2, 4, 6
Efficiency classes:	• IE3 (Premium Efficiency)

Introduction

SIMOTICS motors

General information

1

Benefits

Product highlights

Defined range of options – can be selected according to specific customer requirements. The 1LE0 SIMOTICS FL motor is a standard motor without any built-in options.

Fulfill voltage and construction requirements – The SIMOTICS FL offer additional selection of rated voltages and mounting types.

Upgrade to higher efficiency class – is not available for SIMOTICS FL.

Common user and spare parts – are applicable within the 1LE0 motor series SIMOTICS FL.

Rotatable terminal box

Global support – worldwide warranty and service

Flexible control options

Working with SINAMICS, you can rely on a drive family with flexible control options – with V/f control as well as vector control. As a result, applications can be addressed with basic speed control and with higher speed precision with encoderless vector control or with encoder.

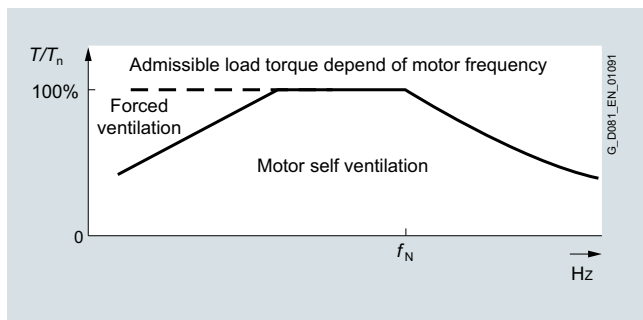

Note:

Forced ventilation is currently not part of the SIMOTICS FL scope.

Application

Application note

- **Pump:** Energy saving for quadratic torque load with variable speed operation
- **Fan:** Ideal for flow control application
- **Material handling:** Effectively working with continuous and intermittent periodic duties. Reliable operation.



Pump

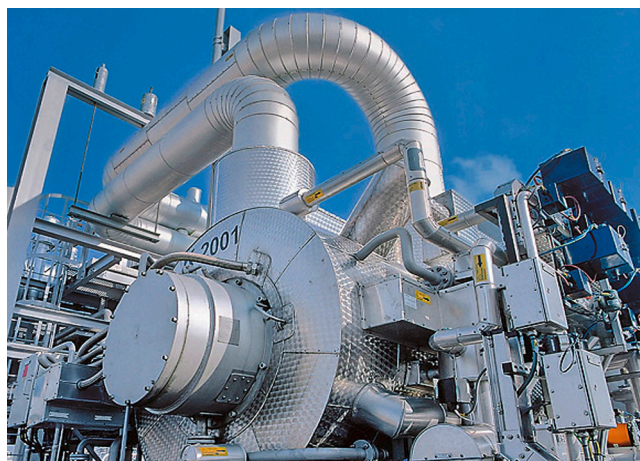

Fan



Material handling

Technical specifications**Key features**

Standard SIMOTICS FL motor is without any build-in options. Defined range of options can be selected according to specific customer requirements.

Besides we can always offer you the most comprehensive motor portfolio made to order for all applications and industries available from our standard catalog portfolio D 81.1.

Low vibration

The low vibration results from our precision manufacturing and the use of defined and controlled quality components. The quality bearings used augment this and result in longer life and lower noise.

For more details, see technical features from page 1/20.

True IP55 as standard

Our IP55 design covers a vast majority of applications and is tested and proven for full lifetime, plus you have the full modification possibility within IP55 rating.

F to B thermal class for built-in reserve

The Siemens motors are rated at normal sinusoidal voltage with a class B (130 °C) temperature rise. The windings are rated to class F (155 °C) thus allowing for reserve for the additional losses associated with variable speed drive operation and / or higher ambient temperature and / or overload conditions when operating directly on line.

F to F is possible for converter operation.

Converter operation for variable speed as standard

For all motors offered up to 460 V converter operation is possible as standard configuration – no special option or series is needed.

Global motor platform

Our motor design is based on one global motor platform with the same look and feel on all low-voltage motor IEC products.

Preparation for easy modifications and mountings

Preparation of the shaft extension at NDE can be ordered with the option "Prepared for mountings, threaded hole only", order code **G46** for the following frame sizes:

Frame size	Threaded hole acc. to DIN 332
80	DR M5
90	DR M6
100	DR M8
112	DR M8
132	DR M10
160	DR M12
180	DR M16
200	DR M20
225	DR M20

The length of the motor does not change because the shaft extension is still under the fan cover.

Introduction

SIMOTICS motors

General information

1

Technical specifications

Special features

		SIMOTICS FL	
		Aluminum series	Cast-iron series
		IE3	IE3
		1LE0323	1LE0043
DOL	Efficiency class		
	Series		
	Voltage up to	690 V	690 V
	Frequency	50 Hz	50 Hz
Converter operation up to		460 V _{rms}	460 V _{rms}
Frame sizes		80 ... 160	180 ... 225
Type of construction	Standard	IM B3	IM B3
	Optional	IM B35, IM B14, IM B5, IM V1, IM B34	IM B35, IM B5, IM V1
Bearing designation	Bearing 62 (DE/NDE)	<input type="checkbox"/>	<input type="checkbox"/>
	Bearing 63 (DE)	<input checked="" type="checkbox"/>	–
	Bearing NU (DE)	–	<input checked="" type="checkbox"/>
Others	Metal fan cover	<input type="checkbox"/>	<input type="checkbox"/>
	Metal rating plate	<input type="checkbox"/>	<input type="checkbox"/>
	Drain hole	<input checked="" type="checkbox"/>	<input checked="" type="checkbox"/>
	Threaded hole at non-drive end prepared for auxiliary mountings	<input checked="" type="checkbox"/>	<input checked="" type="checkbox"/>
	Space heater	<input checked="" type="checkbox"/>	<input checked="" type="checkbox"/>
Motor protection	3 × PTC	<input checked="" type="checkbox"/>	<input checked="" type="checkbox"/>
Certificates, documentation	Extra rating plate for voltage tolerance	<input checked="" type="checkbox"/>	<input checked="" type="checkbox"/>
	CE marking	<input type="checkbox"/>	<input type="checkbox"/>
	Routine test	<input checked="" type="checkbox"/>	<input checked="" type="checkbox"/>
Painting system	C2 standard paint system to EN ISO 12944-2	<input type="checkbox"/>	<input type="checkbox"/>
	Stone gray (RAL 7030)	<input type="checkbox"/>	<input type="checkbox"/>

= Standard

= Option

– = Not possible

For converter operation with the powers specified in the catalog, the motors are used according to temperature class 155 (F), i.e. in this case neither a service factor > 1 nor an increased coolant temperature is possible.

Notes:

All our motors are shown as 400 V as the nominal standard. The IEC 60034 regulations state that the rating plate data is only valid at the specific given voltage. In practice, all listed 400 V motors may be used at connection voltages 400 V ±5%.

The motors will function well, although there would be deviations from the nominal electrical rating plate data.

According to the standard, motors can also be operated at 400 V ±10% (Category B), only longer operation is not recommended.

Overview*Applicable standards and specifications*

Title	IEC
Efficiency classes and efficiencies	IEC 60034-30-1-2014
Rotating electrical machines – Part 1: Rating and performance	IEC 60034-1
Rotating electrical machines – Part 2-1: Standard methods for determining losses and efficiency from tests (excluding machines for traction vehicles)	IEC 60034-2
Rotating electrical machines – Part 5: Degrees of protection provided by the integral design of rotating electrical machines (IP code) – Classification	IEC 60034-5
Rotating electrical machines – Part 6: Methods of cooling (IC Code)	IEC 60034-6
Rotating electrical machines – Part 7: Classification of types of construction, mounting arrangements and terminal box position (IM Code)	IEC 60034-7
Rotating electrical machines – Part 8: Terminal markings and direction of rotation	IEC 60034-8
Rotating electrical machines – Part 9: Noise limits	IEC 60034-9
Rotating electrical machines – Part 14: Mechanical vibration of certain machines with shaft heights 56 mm and higher – Measurement, evaluation and limits of vibration severity	IEC 60034-14
Rotating electrical machines – Part 1: Frame numbers 56 to 400 and flange numbers 55 to 1080	IEC 60072-1
Classification of environmental conditions Part 2-1: Environmental conditions appearing in nature – Temperature and humidity	IEC 60721-2-1
Standard voltages	IEC 60038
Electrical insulation – Thermal classification	IEC 60085

Introduction

Technical features

Voltage and frequency · Tolerances for electrical data

Overview

Voltage and frequency

IEC 60034-1 differentiates between Category A (combination of voltage deviation $\pm 5\%$ and frequency deviation $\pm 2\%$) and Category B (combination of voltage deviation $\pm 10\%$ and frequency deviation $+3\%$ / -5%) for voltage and frequency fluctuations.

The motors can supply their rated torque in both Category A and B. In Category A, the temperature rise is approximately 10 K higher than during normal operation.

Standard 60034-1	Category A	Category B
Voltage deviation	$\pm 5\%$	$\pm 10\%$
Frequency deviation	$\pm 2\%$	3% / -5%
Rating plate data stamped with rated voltage a (e.g. 230 V)	a $\pm 5\%$ (e.g. 230 V $\pm 5\%$)	a $\pm 10\%$ (e.g. 230 V $\pm 10\%$)
Rating plate data stamped with rated voltage ranges b to c (e.g. 220 V to 240 V)	b -5% to c $+5\%$ (e.g. 220 V -5% to 240 V $+5\%$)	b -10% to c $+10\%$ (e.g. 220 V -10% to 240 V $+10\%$)

In Category B, the standard does not recommend extended operation.

The selection and ordering data state the rated current at 400 V. The IEC 60038 standard specifies a tolerance of $\pm 10\%$ for line voltages of 230 V, 400 V and 690 V.

Rotors are dynamically balanced with half key. This corresponds to vibration quantity level A.

Limits (rms values) for max. vibration severity in terms of vibration displacement (s) and vibration velocity (v) for the shaft height H					
Vibration severity grade	Machine installation	Shaft height H in mm			
		$56 \leq H \leq 132$		$H > 132$	
		s_{rms} μm	v_{rms} mm/s	s_{rms} μm	v_{rms} mm/s
A	Free suspension	45	2.8	45	2.8
	Rigid clamping	–	–	37	2.3
B	Free suspension	18	1.1	29	1.8
	Rigid clamping	–	–	24	1.5

For details, see standard EN 60034-14 Aug. 2018, EN 60034-14:2004 + A1:2007

Tolerances for electrical data

- Efficiency η at
 - $P_{rated} \leq 150$ kW: $-0.15 \cdot (1 - \eta)$
 - $P_{rated} > 150$ kW: $-0.10 \cdot (1 - \eta)$
 - With η being a decimal number
- Power factor
 - Power factor $= \frac{1 - \cos \phi}{6}$
 - Minimum absolute value: 0.02
 - Maximum absolute value: 0.07
- Slip $\pm 20\%$ (for motors < 1 kW $\pm 30\%$ is admissible)
- Locked-rotor current $+20\%$
- Locked-rotor torque -15% to $+25\%$
- Breakdown torque -10%
- Moment of inertia $\pm 10\%$

Overview

Standardization of the efficiency classes

Different energy efficiency standards exist worldwide for induction motors: To promote international standardization, the international standard IEC 60034-30-1 03/2014 (Rotating electrical machines – Part 30-1: Efficiency classes of single-speed, three-phase, cage-induction motors (IE code) was created. This groups low-voltage asynchronous motors into new efficiency classes (first released in October 2008).

Applicability (excerpt)

The efficiency classes are grouped according to the following nomenclature (IE = International Efficiency):

- Low-voltage motors up to 1000 V (50/60 Hz with line operation)
- Rating: 0.12 to 1000 kW; with 2, 4, 6, or 8 poles
- Operating mode: S1

The efficiencies in IEC 60034-30-1 are based on the method for determining losses according to IEC 60034-2-1:2014.

Standardization of the efficiency classes

The efficiency classes are grouped according to the following nomenclature (IE = International Efficiency):

- IE1 (Standard Efficiency)
- IE2 (High Efficiency)
- IE3 (Premium Efficiency)
- IE4 (Super Premium Efficiency)

IEC 60034-30-1	NEMA MG1	GB 18613-2012
IE4 ¹⁾		Grade 1 (IE4)
IE3	Premium Efficient (60 Hz)	Grade 2 (IE3)

Comparison of IE efficiency classes

Notes:

All efficiency classes are stated with reference to 50 Hz data (unless specified otherwise).

We comply with the latest efficiency standards and describe motors from IE1 to IE3 efficiencies.

Although Siemens also has ranges for specific solutions for IE4 efficiency, these IE4 types are not in the scope of the SIMOTICS FL series.

Measuring method according to IEC 60034-2-1:2014 for determining the efficiency

With this measuring method, motor losses are no longer applied as a percentage, but are determined by standard methods. The nominal efficiencies are therefore reduced from EFF1 to IE2 and from EFF2 to IE1, even though there have been no technical or physical changes to the motors.

Previously: $P_{LL} = 0.5\% \text{ of } P_1$ (power drawn; IEC 60034-2)
Now: P_{LL} = individual measurement (IEC 60034-1)

P_{LL} = additional load losses

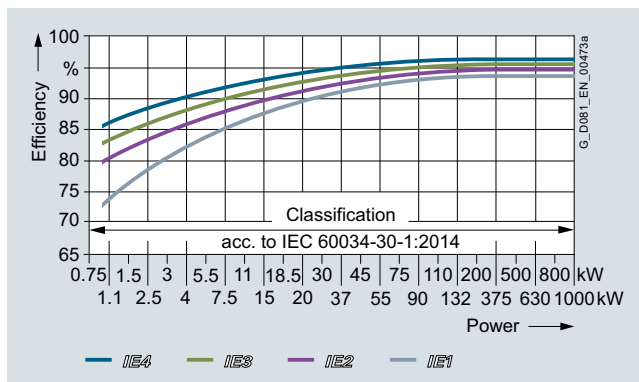

IE1-IE4 efficiencies, 4-pole, 50 Hz, according to power

¹⁾ Defined in IEC/TS 60034-31

Introduction

Technical features

Efficiency classes and efficiencies according to IEC 60034-30-1

1

Overview

Background information

Comprehensive laws have been introduced in the European Union with the objective of reducing energy consumption and therefore CO₂ emissions. EU Regulations 640/2009 and 2019/1781 concern the energy consumption or efficiency of induction motors in the industrial environment. This regulation is in force in every country of the European Economic Area until June 30, 2021.

Effective July 1, 2021, the new regulation (EU) 2019/1781 will come into force. The main contents of and exceptions to both regulations are explained below.

For more information on internationally applicable standards and legal requirements, visit:

www.siemens.com/international-efficiency

Regulation (EC) 640/2009

Exceptions

- Motors that are designed to be operated totally submerged in a liquid;
- Motors fully integrated into a product (e.g. a gear unit, pump, fan or compressor) whose energy efficiency cannot be measured independently of the product;
- Motors that are specially designed for operation under the following conditions:
 - At altitudes greater than 4000 meters above sea level;
 - At ambient temperatures above 60 °C;
 - At maximum operating temperatures above 40 °C;
 - At ambient temperatures below -30 °C
 - With cooling liquid temperatures at the product intake of below 0 °C or above 32 °C;
 - In hazardous areas in the context of Directive 2014/34/EU of the European Parliament and Council;

■ Brake motors

The following motors are not affected:

- Pole-changing motors
- Synchronous motors
- Motors for intermittent duty S2 to S9
- Single-phase motors
- Motors specially developed for converter operation in accordance with IEC 60034-25

The following changes came into effect on the dates below:

From January 1, 2015:

Compliance with the legally required minimum efficiency class IE3 for a power range from 7.5 to 375 kW (2-, 4-, 6-pole) or, as an alternative, IE2 motor plus frequency converter.

From January 1, 2017:

Compliance with the legally required minimum efficiency class IE3 for a power range from 0.75 to 375 kW (2-, 4-, 6-pole) or, as an alternative, IE2 motor plus frequency converter.

From July 1, 2021:

Compliance with the legally required minimum efficiency class IE2 for a power range from 0.12 to 0.75 kW (2-, 4-, 6-, and 8-pole).

From July 1, 2023:

Compliance with the legally required minimum efficiency class IE4 for a power range from 75 to 200 kW (2-, 4- and 6-pole).

New regulation (EU) 2019/1781

Exceptions

- Motors that are designed to be operated totally submerged in a liquid
- Motors fully integrated into a product (e.g. a gear unit, pump, fan or compressor) whose energy efficiency cannot be measured independently of the product
- Motors that are specially designed for operation under the following conditions:
 - At altitudes greater than 4000 meters above sea level
 - Where ambient temperatures exceed 60 °C
 - At maximum operating temperatures above 400 °C
 - At ambient temperatures below -30 °C
 - With cooling liquid temperatures at the product intake of below 0 °C or above 32 °C
 - In hazardous areas as defined in Directive 2014/34/EU of the European Parliament and Council that are designed and certified for underground mining applications
 - Motors with an integrated brake that is an integral part of the interior motor structure and can neither be removed or powered from a separate source during motor efficiency testing.
 - Motors with an integrated speed control (compact drives), whose energy efficiency cannot be tested independently of the speed control

The following motors are not affected:

- Pole-changing motors
- Synchronous motors
- Totally enclosed, naturally ventilated motors (TENV motors);
- Motors specially developed for converter operation in accordance with IEC 60034-25

Other potential restrictions as described in the technical documentation may apply to converter operation and must be taken into account!

The following are generally recommended for converter operation:





- Motor temperature detection by embedded temperature sensor
- Bearing insulation with frame size 225 and larger

Overview

In addition to the basic IM B3 type of construction, motors can also be supplied in other types of construction.

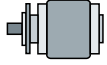
The possible versions in our selection for a particular motor type can be taken from the table below.

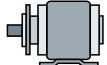
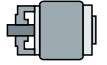
Standard types of construction and special types of construction

Type of construction acc. to IEC 60034-7		Frame size	Letter of the 14th position of the Article No.	Additional identification code -Z with order code
Without flange				
IM B3/IM 1001		80 to 225	A	–
With flange				
IM B5/IM 3001		80 to 225	F	–
IM V1/IM 3011 without protective cover		80 to 225	G	–
IM B35/IM 2001		80 to 225	J	–
With flange				
IM B14/IM 3601		80 to 160	K	–
IM B34/IM 2101		80 to 160	N	–

Apart from the distribution portfolio covered types of construction, here is the general overview of the possible types of construction. Many of them can be achieved by modifying this offered portfolio. Anything else can still be supplied out of our standard catalog portfolio, see D 81.1.

Notes:

When mounting the motors in diverse orientations consider the location of the drain hole – it must be at the lowest point to drain water.

Mounting motors in orientations other than these intended could lead to mechanical or structural premature failure. If in any doubt, please consult your Siemens partner.

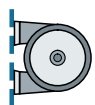
Types of construction according to DIN IEC 34, Part 7

IM B6

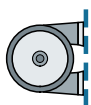

IM B7



IM B8

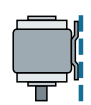

IM V5

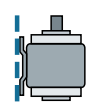

IM V6

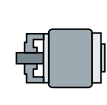

IM B14

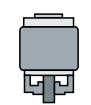

IM V18

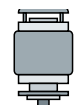

IM V19

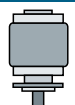

IM V1



IM V3

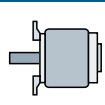

IM B9

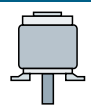

IM V8

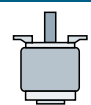

IM V9

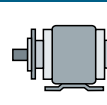

IM B35

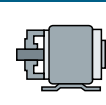

IM B34

Introduction

Technical features

IP rating

Overview

The IP code (or Ingress Protection Rating, sometimes also interpreted as International Protection Rating) consists of the letters IP followed by two digits or one digit and one letter and an optional letter. As defined in international standard IEC 60529, IP code classifies and rates the degrees of protection provided against the intrusion of solid objects, dust, accidental contact, and water in mechanical casings and with electrical enclosures

IP 5 5

Code number indicating protection against water

Code number indicating touch protection and protection against foreign bodies

International Protection

Note:

Some manufacturers offer sealing and protection above IP55. Although it is available as an option, Siemens prefers a true IP55 as a default standard.

- IP55 covers the vast majority of applications as it offers dust and rain protection
- The IP55 is stable over the life of the motor. Higher protections can need maintenance or an exact assembly to ensure that the higher protection is real and not just on paper.
- Modifications can be made on an IP55 motor whilst maintaining that degree of protection.

Solids, first digit

The first digit indicates the level of protection that the enclosure provides against access to hazardous parts (e.g., electrical conductors, moving parts) and the ingress of solid foreign objects.

Level	Object size protected against	Effective against
0	–	No protection against contact and ingress of objects
1	> 50 mm	Any large surface of the body, such as the back of a hand, but no protection against deliberate contact with a body part
2	> 12.5 mm	Fingers or similar objects
3	> 2.5 mm	Tools, thick wires, etc.
4	> 1 mm	Most wires, screws, etc.
5	Dust protected	Ingress of dust is not entirely prevented, but it must not enter in sufficient quantity to interfere with the satisfactory operation of the equipment; complete protection against contact
6	Dust tight	No ingress of dust; complete protection against contact

Note:

A suitable degree of protection should be selected depending on the operating and environmental conditions. Siemens offers a standard which is most suitable and applicable over the lifetime of a motor such as true IP55 standard.

Liquids, second digit

Protection of the equipment inside the enclosure against harmful ingress of water.

Level	Protected against	Testing for	Details
0	Not protected	–	–
1	Dripping water	Dripping water (vertically falling drops) shall have no harmful effect.	Test duration: 10 minutes Water equivalent to 1 mm rainfall per minute
2	Dripping water when tilted up to 15°	Vertically dripping water shall have no harmful effect when the enclosure is tilted at an angle up to 15° from its normal position.	Test duration: 10 minutes Water equivalent to 3 mm rainfall per minute
3	Spraying water	Water falling as a spray at any angle up to 60° from the vertical shall have no harmful effect.	Test duration: 5 minutes Water volume: 0.7 liters per minute Pressure: 80–100 kN/m ²
4	Splashing water	Water splashing against the enclosure from any direction shall have no harmful effect.	Test duration: 5 minutes Water volume: 10 liters per minute Pressure: 80–100 kN/m ²
5	Water jets	Water projected by a nozzle (6.3 mm) against enclosure from any direction shall have no harmful effects.	Test duration: at least 3 minutes Water volume: 12.5 liters per minute Pressure: 30 kN/m ² at distance of 3 m
6	Powerful water jets	Water projected in powerful jets (12.5 mm nozzle) against the enclosure from any direction shall have no harmful effects.	Test duration: at least 3 minutes Water volume: 100 liters per minute Pressure: 100 kN/m ² at distance of 3 m
7	Immersion up to 1 m	Ingress of water in harmful quantity shall not be possible when the enclosure is immersed in water under defined conditions of pressure and time (up to 1 m of submersion).	Test duration: 30 minutes Immersion at depth of 1 m
8	Immersion beyond 1 m	The equipment is suitable for continuous immersion in water under conditions which shall be specified by the manufacturer. Normally, this will mean that the equipment is hermetically sealed. However, with certain types of equipment, it can mean that water can enter but only in such a manner that it produces no harmful effects.	Test duration: continuous immersion in water Depth specified by manufacturer

Overview**Thermal class**

The Siemens motors are rated at normal sinusoidal voltage with a class B (130 °C) temperature rise. The windings are rated to class F (155 °C) thus allowing for reserve for the additional losses associated with variable speed drive operation and/or higher ambient temperature and/or overload conditions.

The temperature rise of the winding of the motor is important. It provides a great insight into the design of the motor and its life expectancy. The cooler a motor runs the better its life expectancy and longer its life. Siemens builds motors to a minimum of class F (155 °C) on all material – continuous operation for a very long life expectancy.

The more efficient the motor, the less heat it produces – to the extent that modern motors often only run with internal temperatures of 95 °C – much cooler than the limits set by the standards.

Siemens uses double coated wires with DURIGNIT insulation materials and capable varnishes – we consider all components including electrical connections and bearing grease – our motors are true class F under all circumstances – with reserve built in on top.

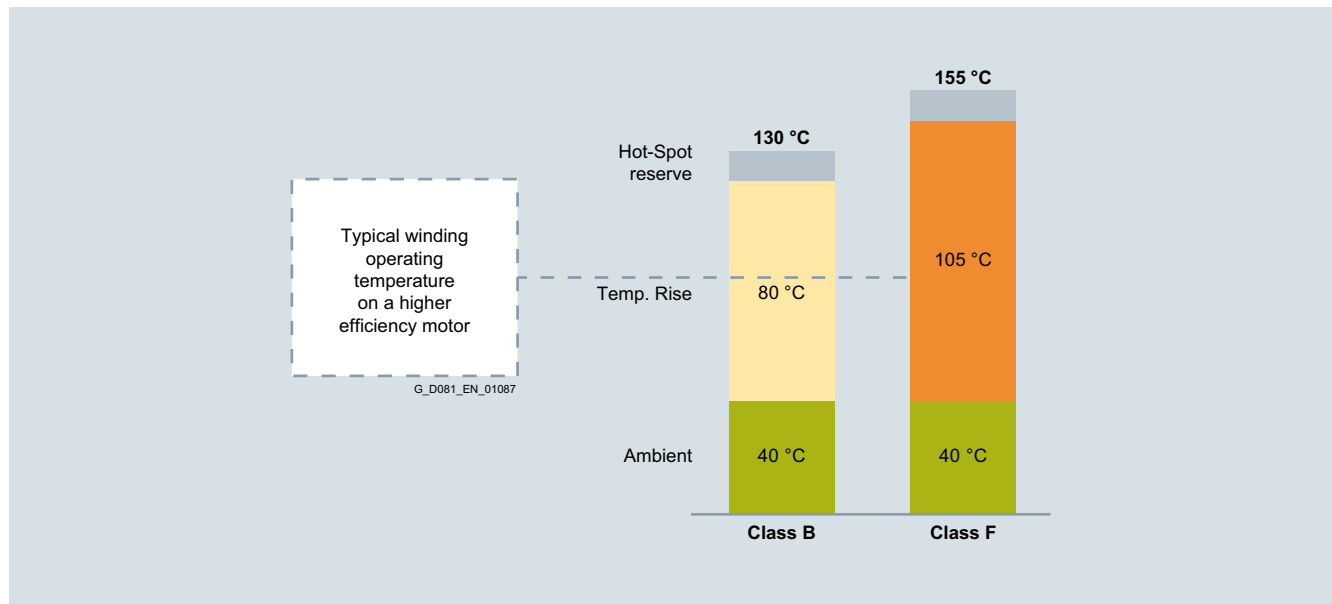
**Note:**

Siemens builds motors with reserve: The motors are capable to operate at least at 155 °C (class F) but we only rate at a nominal 130 °C (class B).

Introduction

Technical features

1

Rating plates

Overview

Examples of rating plates

THREE-PHASE ASYNCHRONOUS MOTOR							
3-Mot. OAV3162A		1LE0323-1DA23-3AA4-Z		LMH-1008 / 800003888993 / 001			
160M	IMB3	IP55	99 kg	Th.Cl.155(F)			
BRG DE: 6209 C3		BRG NDE 6209 C3		IEC60034			
Grease: Unirex N3							
Re-grease interval: 8000h				AMB 40°C			
Quantity: 15g							
V	Hz	kW	A	EFF.(%)	cos φ	r/min	EFF.Cl.
380V Δ/660VY	50	11	20.5/11.9	91.2	0.89	2935	IE3

G_D081_XX_01084

Rating plate for aluminum motor series 1LE0323

THREE-PHASE ASYNCHRONOUS MOTOR							
3-Mot. OCV3182A		1LE0023-1EA23-3AB4-Z		LMH-1008 / 800003888993 / 001			
180M	IMB3	IP55	171 kg	Th.Cl.155(F)			
BRG DE 6210 C3		BRG NDE 6210 C3		IEC60034			
Grease: Unirex N3							
Re-grease interval: 4000h				AMB 40°C			
Quantity: 20g							
V	Hz	kW	A	EFF.(%)	cos φ	r/min	EFF.Cl.
380V Δ/660VY	50	22	40.5/23.5	92.7	0.89	2935	IE3

G_D081_XX_01085

Rating plate for cast-iron motor series 1LE0043

THREE-PHASE ASYNCHRONOUS MOTOR							
3-Mot. OCV3204A		1LE0043-2AA43-4AA4-Z		LMH-2208 / 800003888993 / 001			
200L	IMB35	IP55	219kg	Th.Cl.155(F)			
BRG DE: 6319 C3		BRG NDE 6319 C3		IEC60034			
Grease: Unirex N3							
Re-grease interval: 4000h				AMB 40°C			
Quantity: 20g							
V	Hz	kW	A	EFF.(%)	cos φ	r/min	EFF.Cl.
400V Δ/690VY	50	30	52/30.0	93.3	0.89	2955	IE3

8 Rated voltage and connection

9 Rated frequency

10 Rated power

11 Rated current

12 Efficiency

13 Power factor

14 Rated speed

15 IEC Efficiency class according to IEC standard

16 Ambient temperature

17 QR code

18 IEC standard

19 Product series number

20 Balance method

21 CE mark

22 Thermal class

23 Order No.

24 Motor weight

25 IP protection class

26 Mounting type

G_D081_EN_01033

Explanation of the standard rating plate

Overview**Derating****Environmental**

- Degree of motor protection IP55 (IEC 60034-5).
- Altitude shall not exceed 1000 m above sea level (IEC 60034-1).
- Allowed air temperature between -20 and 40 °C (IEC 60034-1).
- Permitted relative humidity:
 - -20 °C < T < 20 °C: 100%
 - 20 °C < T < 30 °C: 95%
 - 30 °C < T < 40 °C: 55%

For higher coolant temperatures and / or site altitudes higher than 1000 m above sea level, the specified motor must be reduced by using the factor k_{HT} . This results in an admissible output (P_{adm}) of the motor:

$$P_{adm} = P_{rated} \cdot k_{HT}$$

Reduction factor k_{HT} for different site altitudes and/or coolant temperatures

Site altitude above sea level m	Ambient temperature/coolant temperature					
	< 30 °C	30 ... 40 °C	45 °C	50 °C	55 °C	60 °C
1000	1.07	1.00	0.96	0.92	0.87	0.82
1500	1.04	0.97	0.93	0.89	0.84	0.79
2000	1.00	0.94	0.90	0.86	0.82	0.77
2500	0.96	0.90	0.86	0.83	0.78	0.74
3000	0.92	0.86	0.82	0.79	0.75	0.70
3500	0.88	0.82	0.79	0.75	0.71	0.67
4000	0.82	0.77	0.74	0.71	0.67	0.63

Note:

If operating conditions exceed above values, please contact our local sales office for the selection of catalog motors.

Introduction

Technical features

Coolant temperature and installation altitude

Overview

Anti-condensation

Moisture is present in the air around us. Under the correct circumstances it can condensate. The warmer the air the higher the possible moisture content. As air cools the moisture carrying content reduces to the point when the moisture condenses – called the "dew point".

This condition can be met several times a day under normal operation, as a motor operates and cools at differing times of the day.

Smaller motors are less susceptible than larger motors due to the smaller volume of moist air possible in the motor. Dew moisture condenses and accumulates in a motor, which is seen as water collection. The water accumulates at the lowest point of the motor. It often does no harm as long as the collection point is below the level of the electrical system.

Two points that need to be paid attention to are, first, how much water there is in the air and when it will condensate. The second is, whether it will do any harm.

Relative humidity	Temperature							
	20 °C	30 °C	40 °C	50 °C	60 °C	70 °C	80 °C	90 °C
10%	2	3	5	8	13	20	29	42
15%	3	5	8	12	19	30	44	63
20%	3	6	10	17	26	39	58	84
25%	4	8	13	21	32	49	73	105
30%	5	9	15	25	39	59	87	126
35%	6	11	18	29	45	69	102	146
40%	7	12	20	33	52	79	116	167
45%	8	14	23	37	58	89	131	188
50%	9	15	26	41	65	98	145	209
55%	10	17	28	46	71	108	160	230
60%	10	19	31	50	78	118	174	251
65%	11	20	33	54	84	128	189	272
70%	12	21	36	58	91	138	203	293
75%	13	23	38	62	97	148	218	314
80%	14	24	41	66	104	157	233	335
85%	15	26	43	70	110	167	247	356
90%	16	27	46	74	117	177	262	377
95%	16	29	49	79	123	187	276	398
100%	17	30	51	83	130	197	291	419

If operating conditions exceed temperatures of 60 °C, please contact our local sales office for the selection of catalog motors.

The table shows the weight of moisture contained in the air, given as g/m³.

The local temperature is on the X-axis and the local relative humidity is shown on the Y-axis.

Blue fields show normal conditions.

Light gray fields show higher moisture – not available in SIMOTICS FL, only from our standard catalog portfolio D 81.1

Dark gray fields show moisture above 60 g water per m³ of air – not available in SIMOTICS FL, only from our standard catalog portfolio D 81.1

Note:

In humid climates, during motor cool down the air inside contracts, pulling in fresh, warm, humid air. This humidity condensates inside the motor, forming water droplets. Those water droplets have to drain.

Therefore on many motors, especially the larger ones, Siemens has foreseen drain holes as standard. For SIMOTICS FL series they are optionally.

Overview

Anti-condensation heating can be provided for motors where there is a danger that moisture condensation will form on the winding due to the climatic situation. This anti-condensation heater warms up the air in the motor to a temperature above the dew point temperature in order to prevent condensation forming inside the motor. The anti-condensation heating must not be switched on while the motor is operating.

The graphic shows the temperature at which the moisture in the air will condensate to water. The lines on the right show the local temperature. The X-axis gives the local relative humidity. The "dew point" temperature can be read on the Y-axis.

Note:

Another possible solution is to connect a voltage to the stator terminals U1 and V1 that should be between 4 and 10% of the rated motor voltage.

Approximately 20 to 30% of the rated current is sufficient in order to achieve an adequate temperature rise to avoid condensation.

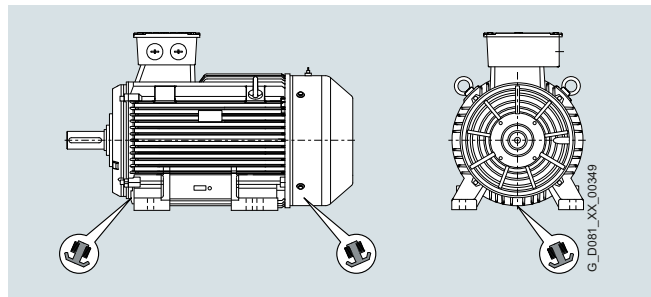
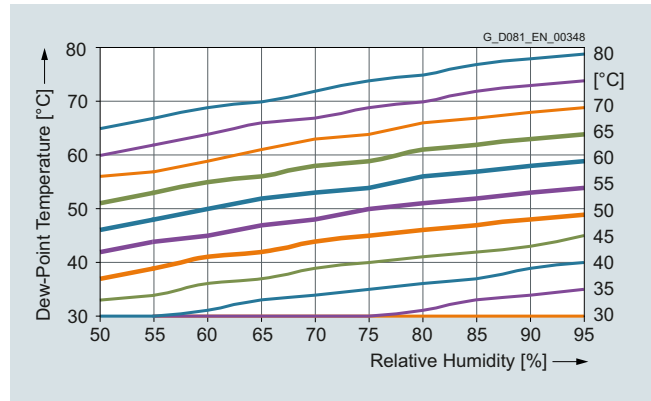

Motor with option code **Q02** and drain hole location

Motor protection**Overview****PTC thermistors – Thermistor motor protection**

PTC thermistor temperature sensors are predominantly used for thermistor motor protection devices (alarm or shutdown) for motors. These thermistors are generally integrated in the winding overhang. As a consequence, the stator winding is directly protected. The temperature difference between alarm and shutdown (trip) is 10 K.

When a limit temperature is reached (nominal tripping temperature), the resistance of PTC thermistors will have a step change. This is evaluated by a tripping unit and can be used to open auxiliary circuits.

Thermal protection with PTC thermistors with 3 embedded temperature sensors for tripping are optionally. Connection can be done through 2 auxiliary terminals in the terminal box.

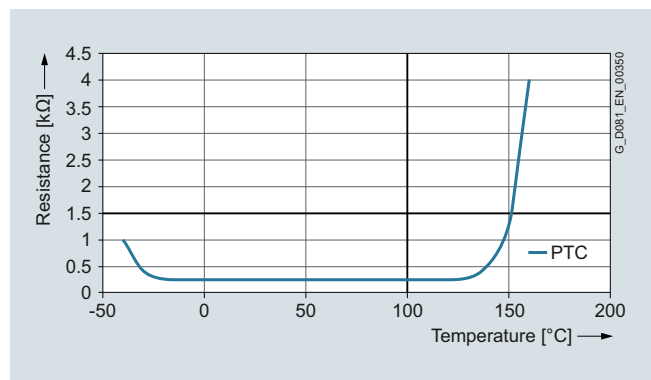
Note:

The PTC thermistors themselves cannot be subjected to high currents and voltages. This would result in destruction of the semiconductor. The switching hysteresis of the PTC thermistor and tripping unit is low, which supports fast restarting of the drive. Motors with this type of protection are recommended for heavy duty starting, switching duty, extreme changes in load, high ambient temperatures or fluctuating supply systems.

Introduction

Technical features

Converter operation

1

Overview

Converter application

The insulation system of our motors is capable for converter operation as standard.

Our motors are suitable e.g. for pumps, fans, compressors, textile machines and mechanical machine applications where variable or constant speed is required.

In applications where the motor is driven by a converter, the degree of electrical interference depends on the type of converter used (type, number of IGBTs, interference suppression measures, and manufacturer), cabling, distance and application requirements. The installation guidelines of the converter manufacturer with regards to electromagnetic compatibility must be considered at all times during the design and implementation phases.

At rated output with converter operation, the motors will be used in temperature class 155 (F). To prevent damage as a result of bearing currents, insulated bearings are recommended to be assembled for frame size 250 and above. Please inquire Siemens about the detailed information of insulated bearing.

Converter operation

The standard insulation of our motors is designed such that operation is possible on the converter at mains voltage up to 460 V.

Our motors are capable for converter operation with certain characteristics load, of which the load torque characteristics is referred in the following diagram:

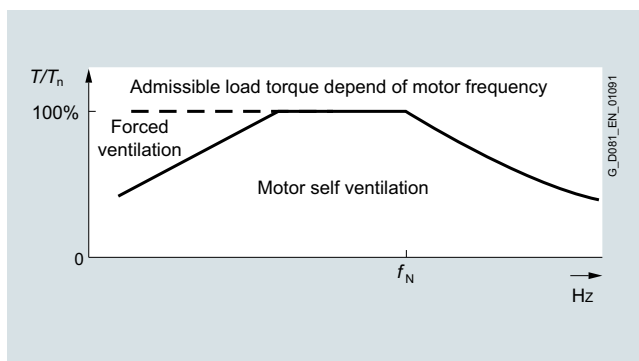

By usage with admissible torque and below, the motor can be operated with self cooling; by usage over the admissible torque line, the motor with forced ventilation is needed. Forced ventilation is currently not part of the SIMOTICS FL scope.

Note:

These motors do not have a special series for converter operation – they are suited as standard direct-on-line operation or converter operation.

At operating speeds above rated speed the noise and vibration levels increase and the bearing lifetime reduces. Attention should be paid to the re-greasing intervals and the grease service life. For converter operation with frequencies greater than 60 Hz special balancing is required for compliance with the specified limit values.

Overview**Mechanical stress and grease lifetime (converter operation).**

High speeds that exceed the rated speed and the resulting increased vibrations alter the mechanical running smoothness and the bearings are subject to increased mechanical stress. This reduces the grease lifetime and the bearing lifetime. More detailed information on request.

Ventilation/noise generation (converter operation)

The fan noise can increase at speeds that are higher than the rated speed of self-ventilated motors. To increase motor utilization at low speeds it is recommended that forced ventilated motors are used.

Mechanical limit speeds

When the motor is operated at its rated frequency, it is important to note that the maximum speeds are limited by the limits for the bearings, critical rotor speed and rigidity of the rotating parts.

With converter operation, the reduction factors for constant torque and drives for fans, pumps and compressors must be observed.

Mechanical limit speeds n_{max} at maximum supply frequency f_{max} for SIMOTICS FL

Frame size	Mechanical speed limit					
	2-pole		4-pole		6-pole	
	n_{max} rpm	f_{max} Hz	n_{max} rpm	f_{max} Hz	n_{max} rpm	f_{max} Hz
80	3600	60	3000	100	2000	100
90	3600	60	3000	100	2000	100
100	3600	60	3000	100	2000	100
112	3600	60	3000	100	2000	100
132	3600	60	2700	90	2000	100
160	3600	60	2700	90	2000	100
180	3600	60	2700	90	2000	100
200	3600	60	2300	77	1800	90
225	3600	60	2300	77	1800	90

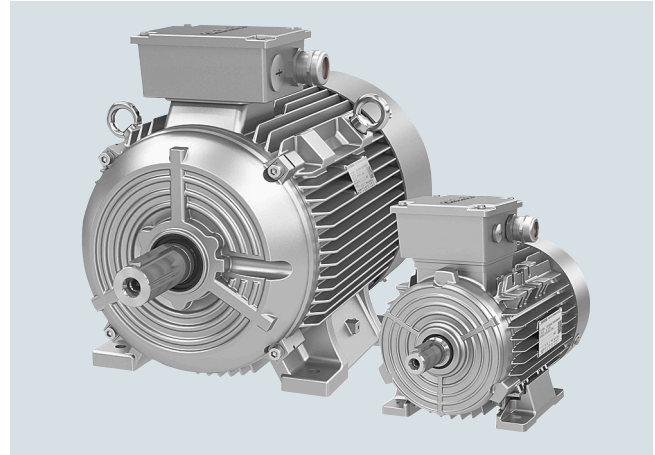
**Note:**

By use of converter operation, motors can run at speeds higher than 50 Hz nominal speed. High speeds that exceed the rated speed of a motor can lead to increased vibration and substantially decrease the life expectancy of the bearings. The maximum mechanical speed of a motor must not be exceeded due to risk of failure. More detailed information on request.

Introduction

Technical features

Noise levels

Overview

Motors are often used in applications in which noise is a primary concern. The use of converters can excite the surfaces of motors and the sound of diverse frequencies can be resonated in the cooling channels.

Siemens has addressed this issue by modifying the core design. Surfaces, shapes and materials and air channels have been optimized. The result is a motor which is quieter, especially with converter operation.

In order to define the motor noise level, the A-weighted sound pressure level ($L_{p(A)}$) is measured at several points on the measuring plane (1 m away from the motor surface).

The measurement is carried out in a room with low reflection. As a result of noise reflection, the level can be increased up to 3 dB (A) depending on the acoustic properties of the surroundings.

The A sound power level (L_{WA}) is normally used when engineering projects and when it is necessary to determine the noise radiated from a group of motors whose envelope dimensions differ significantly.

For sound power level, see "Selection and ordering data" from page 2/3.

Bearings and lubrication

Overview

The bearings are especially important in order that the motor runs perfectly. A good selection of bearing will guarantee long lubrication intervals, low noise, low-vibration operation and longer lifetime as well.

There are many types of bearing: diverse ball and roller bearings, tapered roller bearings and specialized bearings. Siemens has selected an applicable range of single-shielded and double-shielded bearings. Z for when regreasing is needed and ZZ when no regreasing is wished for.

Sealed-for-life bearings are avoided as they bring inherent disadvantages in operation temperatures and limit operating speeds.

Special bearings are avoided due to their disadvantages outside of their specific application.

Note:

Factors that reduce the lifetime of a bearing:

- Operating a motor beyond the rated speed increases the motor vibration and results in an additional radial and axial force on the bearing.
- Increased motor vibration due to the environment or other equipment results in a higher radial and axial force.

The bearing lifetime of motors with horizontal type of construction is at least 40000 hours if there is no additional axial loading at the coupling output and at least 20000 hours with the maximum admissible loads.

This assumes that the motor is operated at 50 Hz.

A bearing is only as good as its lubrication. Siemens designed a special lithium complex grease – Unirex N3.

It gives a super thermal stability for optimized bearing life. The grease gives a great temperature range from –30 to 130 °C – with an intermittent temperature reserve to 165 °C.

Grease lifetime and regreasing intervals for horizontal installation

Motor series	Frame size	No. of poles	Grease lifetime up to CT 40 °C
Permanent lubrication			
1LE0	80 ... 160	2	20000 h
		4, 6	40000 h
	180 ... 225	2	20000 h
		4, 6	40000 h
Regreasing device(L23)			
1LE0	100 ... 160	2, 4, 6	8000 h
		2	4000 h
	180 ... 225	4, 6	8000 h

Overview**Cantilever force**

This force acts transversely at the center line of the motor shaft extension. The cantilever force is calculated from the circumferential force multiplied by the pre-tension factor, which is dependent on the mechanical transmission characteristics of the particular belt.

For motors with deep-groove ball bearings, the permissible cantilever force can be increased by replacing the bearings at the drive end with cylindrical roller bearings.

In order to calculate the admissible cantilever forces for a radial load, the line of force (i.e. the center line of the pulley) of the cantilever force F_Q (N) must lie within the free shaft extension (dimension x).

Dimension x (mm) is the distance between the point of application of force F_Q and the shaft shoulder.

Dimension x_{\max} corresponds to the length of the shaft extension. Total cantilever force is calculated using the following equation.

$$F_Q = c \cdot F_u$$

The pre-tension factor c is a value gained from experience by the belt manufacturer. The following approximate value can be assumed.

- For normal flat leather belts with an idler pulley, $c = 2$.
- For V-belts, $c = 2$ to 2.5.
- For special synthetic belts (depending on the type and load), $c = 2$ to 2.5.

The circumferential force F_u (N) is calculated using the following equation.

$$F_u = 2 \cdot 10^7 \frac{P}{n \cdot D}$$

- F_u circumferential force in N
- P rated motor power (transmitted power) in kW
- n rated motor speed in rpm
- D belt pulley diameter in mm.

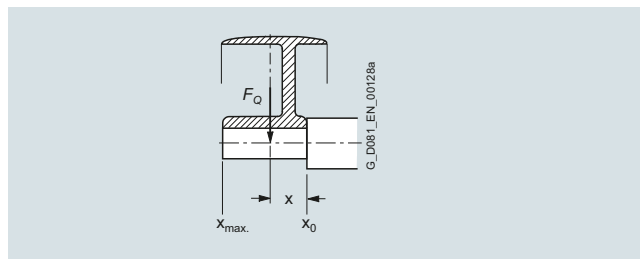
**Belt drive**

A belt drive is used to connect two parallel shafts, the motor shaft with the shaft of the driven machine, whereby the speed can be simultaneously changed corresponding to the ratio between the two belt pulley diameters.

The belt must be pre-tensioned so that it can transmit the circumferential force through friction. The pre-tension factor indicates how much higher the actual tension load (cantilever force) is than the circumferential force (peripheral force).

Today, flat belts are almost always manufactured out of plastic with an adhesive coating (e.g. chrome leather).

Pre-tension factor, approx. 2 to 2.5.

The pre-tension factor for V-belts is approx. 1.5 to 2.5.

The belt must be able to transmit the power at the defined circumferential velocity. This defines the belt thickness and width. The belt supplier specifies the pre-tension factor.

The recommended circumferential velocity is approx. 35 m/s for flat belts and approx. 25 m/s for V-belts.

Steel belt pulleys must be used for circumferential velocities greater than 26 m/s due to the centrifugal force which occurs.

The actual cantilever force (belt tension) must be compared with the cantilever force permissible for the motor to select the correct motor and bearing sizes.

Introduction

Technical features

Bearings and lubrication

1

Overview

Bearing selection table for 1LE0 motors – basic version

Frame size	No. of poles	Drive end (DE) bearing		Non-drive end (NDE) bearing	
		Horizontal and vertical types of construction		Horizontal and vertical types of construction	
1LE0323					
80	2 ... 6	6204 2Z C3		6204 2Z C3	
90	2 ... 6	6205 2Z C3		6205 2Z C3	
100	2 ... 6	6206 2Z C3		6206 2Z C3	
112	2 ... 6	6206 2Z C3		6206 2Z C3	
132	2 ... 6	6208 2Z C3		6208 2Z C3	
160	2 ... 6	6209 2Z C3		6209 2Z C3	
1LE0043					
180	2 ... 6	6210 Z C3		6210 Z C3	
200	2 ... 6	6212 Z C3		6212 Z C3	
225	2 ... 6	6213 Z C3		6213 Z C3	

Bearing selection table for 1LE0 motors – bearings for increased cantilever forces – order code L22

Frame size	No. of poles	Drive end (DE) bearing		Non-drive end (NDE) bearing	
		Horizontal and vertical types of construction		Horizontal and vertical types of construction	
1LE0323					
80	2 ... 6	–		–	
90	2 ... 6	–		–	
100	2 ... 6	6306 2Z C3		6206 2Z C3	
112	2 ... 6	6306 2Z C3		6206 2Z C3	
132	2 ... 6	6308 2Z C3		6208 2Z C3	
160	2 ... 6	6309 2Z C3		6209 2Z C3	
1LE0043					
180	2 ... 6	NU210		6210 Z C3	
200	2 ... 6	NU212		6212 Z C3	
225	2 ... 6	NU213		6213 Z C3	

Note:

When the load pulls sideways on the shaft, it is called a radial load. A heavy radial load is a belt or pulley drive. If in doubt, it is common to use or strengthened bearings.

Overview

Bearings – Cantilever forcesAdmissible cantilever forces – basic version**1LE0 motors (frame sizes 80 ... 225)**Valid are: x_0 values for $x = 0$ and x_{max} values for $x = l$ (l = shaft extension)

Frame size	No. of poles	Admissible cantilever force F_Q	
		at x_0	at x_{max}
1LE0323 motors – values for IE3 motors			
80	2	620	510
	4	790	640
	6	910	740
90	2	700	560
	4	880	720
	6	1020	820
100	2	980	790
	4	1230	990
	6	1420	1140
112	2	980	790
	4	1230	990
	6	1420	1140
132	2	1440	1120
	4	1820	1420
	6	2080	1630
160	2	1560	1240
	4	1970	1570
	6	2260	1800
1LE0043 motors – values for IE3 motors			
180	2	1820	1470
	4	2300	1900
	6	2630	2150
200	2	2650	2230
	4	3350	2800
	6	3850	3230
225	2	3000	2540
	4	3700	3000
	6	4250	3470

Admissible cantilever forces – bearings for increased cantilever forces – order code **L22****1LE0 motors (frame sizes 80 ... 225) at 50 Hz with reinforced deep-groove bearings at DE**Valid are: x_0 values for $x = 0$ and x_{max} values for $x = l$ (l = shaft extension)

Frame size	No. of poles	Admissible cantilever force F_Q	
		at x_0	at x_{max}
1LE0323 motors – values for IE3 motors			
80	2	–	–
	4	–	–
	6	–	–
90	2	–	–
	4	–	–
	6	–	–
100	2	1480	1220
	4	1870	1540
	6	2140	1720
112	2	1480	1220
	4	1870	1540
	6	2140	1720
132	2	2100	1700
	4	2720	2170
	6	3100	2420
160	2	2650	2120
	4	3300	2600
	6	3750	2900
1LE0043 motors – values for IE3 motors			
180	2	3300	2700
	4	4200	3400
	6	4750	3900
200	2	5000	4200
	4	6330	5320
	6	7250	6080
225	2	5650	4800
	4	6950	5600
	6	7900	6500

Introduction

Technical features

Terminal boxes

1

Overview

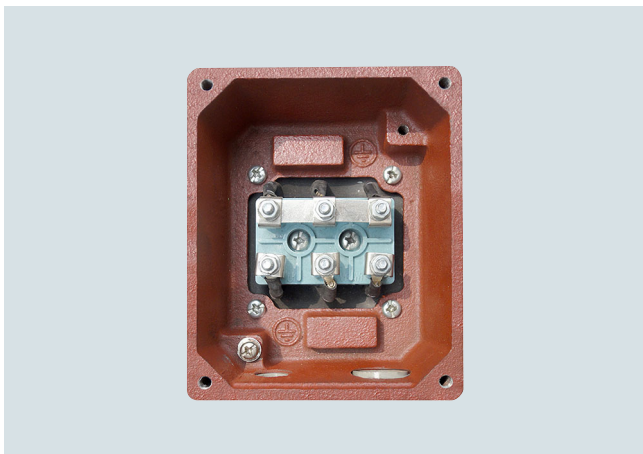

Technical specifications for terminal boxes for 1LE0 motors

Frame size	Number of terminals	Max. auxiliary terminals	Thread of the contact screw	Max. connectable cable mm ²	Outer cable diameter (sealing end) mm	Cable entry
1LE0323						
80	6	12	M4	1,5	13 ... 18	M25 × 1.5 + M16 × 1.5
90				4		
100						
112						
132						
160			M5	16		M36 × 2 + M36 × 2
1LE0043						
180	6	14	M5	16	22 ... 32	M40 × 1.5 + M40 × 1.5
200			M6	25	32 ... 38	M50 × 1.5 + M50 × 1.5
225			M8	35		

Packaging

Overview

Packaging size

Frame size	Packaging size mm		
	IE3 efficiency		
	1LE0		
	Length	Width	Height
80	395	225	280
90	455	225	290
100	515	275	335
112	555	275	350
132	665	335	405
160	730	460	590
180	910	460	630
200	1040	510	680
225	1120	560	730

Overview

Handling and storage

When lifting the motors, always use the lifting eyes provided. Prior to lifting the motor make sure that the lifting eyes are installed correctly and tightened. Never lift a motor using the rotor shaft and fan cover. In addition, care must be taken during lifting and lowering of the motor to avoid any shocks or vibrations which can result in bearing damages.

It is recommended that all motors be stored in a dry, dust-free environment and free of excessive vibrations.

If the DE and NDE bearings are of the sealed types, it is recommended that they are replaced if storage has exceeded 2 years from date of motor manufacture. If the motors have the regreasable bearings, then the recommendation is to replace the grease after 2 years of storage.

The service life of the motor can be considerably reduced if the storage period extends beyond 2 years in environments with high moisture and dirt. If necessary, the insulation resistance of the winding could be measured to determine the health of the motor prior to installation and start-up.

Machined surfaces (flange, DE rotor shaft) are treated at the factory with an anticorrosive agent to prevent rusting. However, these surfaces should be retreated during storage as deemed necessary. It is recommended that the motor shaft is rotated by hand on a frequent basis to ensure even grease distribution.

Certificates

ISO 9001 Quality Management System Certificate and ISO 14001 Environmental Management System Certificate



G_D081_XX_01088

Introduction

Technical features

Rated power, rated torque, speed

Overview

Rated power

Power is the work performed in a unit of time, measured in W (Watt).

Dimensions:

$$\begin{aligned} 1 \text{ W} &= \text{J/s (1 Joule per second)} \\ &= 1 \text{ Nm/s (1 Newton meter per second)} \\ &= 1 \text{ kgm}^2/\text{s}^3 \\ &= 0.102 \text{ kpm/s} \\ 1 \text{ kW} &= 1.36 \text{ hp} \end{aligned}$$

The following applies to three-phase motors:

$$P_N = \sqrt{3} \cdot V_{\text{supply}} \cdot I_{\text{supply}} \cdot \eta \cdot \cos\phi$$

P_N	Rated power in W
V	Rated voltage in V
I	Line current in A
η	Efficiency
$\cos\phi$	Power factor

The rated power is one of the most important parameters of a motor. According to DIN 42673 – and maintaining the regulations according to VDE 0530 – the individual motor frame sizes are assigned specific power ratings for continuous duty S1. Different operating conditions or different duty types generally result in a change in the rated power.

Rated torque

Torque is generated by the effect of force applied to a lever arm. This is the product of force multiplied by the vertical distance from the axis of rotation; for belt drives, e.g. circumferential force multiplied by the radius of the belt pulley.

$$T = \frac{9.55 \cdot P \cdot 1000}{n}$$

M	Torque in Nm
P	Power in kW
n	Speed in rpm

Speed

The synchronous speed n_s (rpm) of a three-phase induction motor is obtained from the line frequency f and the pole pair number p (4-pole $\rightarrow 2p = 4$).

$$n_s = \frac{120 \cdot f}{2 \cdot p}$$

When connected to a 50 Hz line supply, a $2p = 4$ -pole motor has a synchronous speed of

$$\frac{120 \cdot 50}{4} = 1500 \text{ rpm}$$

The synchronous speeds of the generally used 2, 4, and 6-pole motors are correspondingly obtained at a line frequency of 50 Hz 3000, 1500, 1000 rpm

The rotor of a three-phase induction motor rotates with a lower speed (with slip) than the rotating field.

Slip s is calculated according to the following formula:

$$s_{\text{rated}} = \frac{n_s - n_{\text{rated}}}{n_s} \cdot 100$$

s	Slip as a%
n_s	Synchronous speed in rpm
n	Rotor speed in rpm

The rated slip s_N is correspondingly calculated.

The rotor losses of the motor are approximately proportional to the slip. The objective is to achieve a low rated slip in order to achieve a good efficiency.

The rated slip depends on the motor size.

For instance, for small motors, it is approx. 10% and for large motors, approx. 1%.

SIMOTICS FL standard motors



2/2	Orientation
2/2	Article number code
2/3	Flow Line · IE3 Premium Efficiency
2/3	Aluminum series SIMOTICS FL
	• 1LE0323
2/3	Cast-iron series SIMOTICS FL
	• 1LE0043
2/6	Article No. supplements and special versions
2/6	Voltages
2/7	Types of construction
2/8	Motor protection
2/8	Terminal box position
2/9	Options
2/10	Dimensions · Aluminum series SIMOTICS FL
	IE3
2/10	• Frames sizes 80 M to 160 L
2/12	Dimensions · Cast-iron series SIMOTICS FL
	IE3
2/12	• Frames sizes 180 L to 225 L
2/14	Flange dimensions

SIMOTICS FL standard motors

Orientation

Article number code

Selection and ordering data

The article number consists of a combination of figures and letters and is divided into three blocks linked with hyphens for a better overview, e.g.:

**1LE0323-0DA22-2AA4-Z
H03**

The first block (positions 1 to 7) identifies the motor type. The second block (positions 8 to 12) defines the motor frame size and length, the number of poles and power and in some cases the frequency/voltage. In the third block (positions 13 to 16), the frequency/voltage, type of construction and further design features are encoded.

For deviations in the second and third block from the catalog codes either **Z** should be used as appropriate.

Ordering data:

- Complete Article No. and order code(s) or plain text
- If a quotation has been requested, please specify the quotation number in addition to the Article No.
- When ordering a complete motor as a spare part, please specify the works serial No. for the previously supplied motor as well as the Article No.

Structure of the Article No.:	Position:	1	2	3	4	5	6	7	-	8	9	10	11	12	-	13	14	15	16	
1st to 4th position: Digit, letter, letter, digit	• Flow Line – self-ventilated by a fan mounted on and driven by the rotor	1	L	E	0															
5th and 6th position: 2 digits	Aluminum housing Cast-iron housing					3	2													
7th position: Digit	Motors with IE3 Premium Efficiency							3												
8th, 9th and 11th position: Digit, letter, digit	Motor frame size (frame size as a combination of shaft height and overall length, encoded)									0	D		0							
10th position: Letter	No. of poles A: 2-pole, B: 4-pole, C: 6-pole									2	B		5							
12th and 13th position: 2 digits	Voltage, circuit and frequency (encoded with two digits)													2		1				
14th position: Letter	Type of construction (encoded with A ... N)																A			
15th position: Letter	Motor protection A: without winding protection B: PTC thermistors for tripping																	A		
16th position: Digit	Terminal box position 4: Terminal box top																		4	
	Special order versions: encoded – additional order code required																			- Z

Ordering example

Selection criteria	Requirement	Structure of the Article No.
Motor type 1LE0	Standard motor with IE3 Premium Efficiency, IP55 degree of protection, cast-iron housing	1LE0043-■■■■■■-■■■■■
Motor frame size/No. of poles/Speed	180 M/2-pole/3000 rpm	1LE0043-1EA2■-■■■■■
Rated power	22 kW	
Voltage and frequency	400 VΔ/690 VY, 50 Hz	1LE0043-1EA23-4■■■■
Type of construction with special version	IM B3 (standard)	1LE0043-1EA23-4A■■■-Z H03
Motor protection	Without protection	1LE0043-1EA23-4AA■-Z H03
Terminal box position	Terminal box top	1LE0043-1EA23-4AA4-Z H03



Aluminum series SIMOTICS FL 1LE0323 and cast-iron series SIMOTICS FL 1LE0043 – self-ventilated

Selection and ordering data

P _{rated} , 50 Hz/ P50	Frame size	IE class	Operating values at rated power										L _{pfA} , 50 Hz	L _{WA} , 50 Hz	Aluminum series 1LE0323 Cast-iron series 1LE0043 Article No.	m _{IM B3}	J		
			η _{rated} 50 Hz	T _{rated} 50 Hz	η _{rated} 50 Hz, 4/4	η _{rated} 50 Hz, 3/4	η _{rated} 50 Hz, 2/4	cos φ _{rated} 50 Hz, 4/4	I _{rated} 50 Hz, 400 V	Start- ing cur- rent	Start- ing torque	Break down torque						dB(A)	dB(A)
kW	FS		rpm	Nm	%	%	%	A											
<ul style="list-style-type: none"> • Cooling: Self-ventilated (IC 411) • Efficiency according to IEC 60034-30: IE3 Premium Efficiency • Insulation: Thermal class 155 (temperature class F), IP55 degree of protection, utilization in accordance with thermal class 130 (temperature class B) 																			
2-pole: 3000 rpm at 50 Hz, 230 VΔ / 400 VY																			
0.75	80 M	IE3	2835	2.5	80.7	82.9	82.9	0.86	1.56	6.0	2.6	3.0	54	65	1LE0323-0DA22-2	12.5	0.00208		
1.1	80 M	IE3	2850	3.7	82.7	84.0	83.9	0.83	2.30	6.5	2.6	3.4	54	65	1LE0323-0DA32-2	13	0.00154		
1.5	90 S	IE3	2870	5.0	84.2	84.8	82.3	0.86	3.00	7.0	2.0	3.0	58	70	1LE0323-0EA02-2	18	0.00276		
2.2	90 L	IE3	2890	7.3	85.9	87.2	86.5	0.88	4.20	7.5	2.8	3.6	58	70	1LE0323-0EA42-2	22	0.00356		
3	100 L	IE3	2865	10.0	87.1	88.3	88.3	0.87	5.7	8.0	3.7	3.6	60	72	1LE0323-1AA42-2	29	0.00462		
4	112 M	IE3	2915	13.1	88.1	89.6	89.8	0.90	7.3	7.8	2.6	3.6	62	74	1LE0323-1BA22-2	36	0.00879		
5.5	132 S	IE3	2930	17.9	89.2	90.2	90.3	0.89	10.0	7.5	2.3	3.6	65	77	1LE0323-1CA02-2	50	0.01847		
7.5	132 S	IE3	2930	24.4	90.1	91.5	92.2	0.90	13.4	7.5	2.3	3.6	65	77	1LE0323-1CA12-2	56	0.02323		
2-pole: 3000 rpm at 50 Hz, 400 VΔ / 690 VY																			
3	100 L	IE3	2865	10.0	87.1	88.3	88.3	0.87	5.7	8.0	3.7	3.6	60	72	1LE0323-1AA43-4	29	0.00462		
4	112 M	IE3	2865	10.0	87.1	88.3	88.3	0.87	5.7	8.0	3.7	3.6	60	72	1LE0323-1BA23-4	36	0.00879		
5.5	132 S	IE3	2915	13.1	88.1	89.6	89.8	0.90	7.3	7.8	2.6	3.6	62	74	1LE0323-1CA03-4	50	0.01847		
7.5	132 S	IE3	2930	17.9	89.2	90.2	90.3	0.89	10.0	7.5	2.3	3.6	65	77	1LE0323-1CA13-4	56	0.02323		
11	160 M	IE3	2930	24.4	90.1	91.5	92.2	0.90	13.4	7.5	2.3	3.6	65	77	1LE0323-1DA23-4	84	0.03903		
15	160 M	IE3	2935	35.8	91.2	92.0	91.7	0.89	19.6	7.5	2.3	3.4	69	81	1LE0323-1DA33-4	94	0.0472		
18.5	160 L	IE3	2935	48.8	91.9	92.6	92.5	0.89	26.5	7.5	2.4	3.4	69	81	1LE0323-1DA43-4	109	0.05773		
22	180 M	IE3	2935	60.2	92.4	93.0	92.9	0.89	32.5	7.8	2.4	3.4	69	81	1LE0043-1EA23-4	162	0.0835		
30	200 L	IE3	2950	71.2	92.7	93.0	92.4	0.89	38.5	7.8	2.4	3.4	70	83	1LE0043-2AA43-4	219	0.146		
37	200 L	IE3	2955	97	93.3	93.4	92.4	0.89	52	7.8	2.4	3.4	71	84	1LE0043-2AA53-4	248	0.181		
45	225 M	IE3	2960	119	93.7	93.9	93.3	0.89	64	8.5	2.6	3.4	71	84	1LE0043-2BA23-4	322	0.301		
Voltages																Order code			
For other voltages and more information, see from page 2/6																...			
Types of construction										Version				Order code					
Without flange		IM B3								Standard				A		-			
For other types of construction and more information, see from page 2/7																...			
Motor protection										Version				Order code					
Without								Standard				A		-					
For other motor protection and more information, see from page 2/8																...			
Terminal box position										Version				Order code					
Terminal box at top								Standard				4		-					
Special versions														Order code					
For options, see from page 2/9																1LE0...-.....-Z-+...+...+...			



SIMOTICS FL standard motors

Flow Line · IE3 Premium Efficiency



Aluminum series SIMOTICS FL 1LE0323 and cast-iron series SIMOTICS FL 1LE0043 – self-ventilated

Selection and ordering data

P _{rated} , 50 Hz/ P50	Frame size	IE class	Operating values at rated power										L _{pfA} , 50 Hz	L _{WA} , 50 Hz	Aluminum series 1LE0323 Cast-iron series 1LE0043 Article No.	m _{IM B3}	J						
			η _{rated} 50 Hz	T _{rated} 50 Hz	η _{rated} 50 Hz, 4/4	η _{rated} 50 Hz, 3/4	η _{rated} 50 Hz, 2/4	cos φ _{rated} 50 Hz, 4/4	I _{rated} 50 Hz, 400 V	Start- ing current	Start- ing torque	Break down torque											
kW	FS		rpm	Nm	%	%	%		A					dB(A)	dB(A)		kg	kgm ²					
<ul style="list-style-type: none"> • Cooling: Self-ventilated (IC 411) • Efficiency according to IEC 60034-30: IE3 Premium Efficiency • Insulation: Thermal class 155 (temperature class F), IP55 degree of protection, utilization in accordance with thermal class 130 (temperature class B) 																							
4-pole: 1500 rpm at 50 Hz, 230 VΔ / 400 VY																							
0.55	80 M	IE3	1445	3.6	80.8	81.8	80.2	0.76	1.29	5.5	2.2	3.2	45	56	1LE0323-0DB22-2	11	0.00216						
0.75	80 M	IE3	1440	5.0	82.5	82.9	80.7	0.75	1.75	6.0	2.6	3.7	45	56	1LE0323-0DB32-2	13	0.00250						
1.1	90 S	IE3	1445	7.3	84.1	85.1	83.9	0.79	2.4	6.5	2.7	3.7	47	59	1LE0323-0EB02-2	18.5	0.00389						
1.5	90 L	IE3	1445	9.9	85.3	86.0	85.2	0.79	3.2	6.5	2.8	3.8	47	59	1LE0323-0EB42-2	22	0.00499						
2.2	100 L	IE3	1445	14.5	86.7	87.1	85.7	0.81	4.5	8.3	3.4	4.6	52	64	1LE0323-1AB42-2	32	0.01125						
3	100 L	IE3	1440	19.9	87.7	88.1	87.1	0.81	6.1	8.3	3.7	4.6	52	64	1LE0323-1AB52-2	36	0.01313						
4	112 M	IE3	1450	26.3	88.6	89.6	89.2	0.81	8.0	7.8	3.7	4.6	53	65	1LE0323-1BB22-2	43	0.01493						
5.5	132 S	IE3	1455	36.1	89.6	90.9	91.1	0.84	10.5	7.8	2.6	3.8	59	71	1LE0323-1CB02-2	58	0.02847						
7.5	132 M	IE3	1455	49.2	90.4	91.7	93.2	0.85	14.1	7.8	2.6	3.8	59	71	1LE0323-1CB22-2	71	0.03561						
4-pole: 1500 rpm at 50 Hz, 400 VΔ / 690 VY																							
2.2	100 L	IE3	1445	14.5	86.7	87.1	85.7	0.81	4.5	8.3	3.4	4.6	52	64	1LE0323-1AB43-4	32	0.01125						
3	100 L	IE3	1440	19.9	87.7	88.1	87.1	0.81	6.1	8.3	3.7	4.6	52	64	1LE0323-1AB53-4	36	0.01313						
4	112 M	IE3	1450	26.3	88.6	89.6	89.2	0.81	8.0	7.8	3.7	4.6	53	65	1LE0323-1BB23-4	43	0.01493						
5.5	132 S	IE3	1455	36.1	89.6	90.9	91.1	0.84	10.5	7.8	2.6	3.8	59	71	1LE0323-1CB03-4	58	0.02847						
7.5	132 M	IE3	1455	49.2	90.4	91.7	93.2	0.85	14.1	7.8	2.6	3.8	59	71	1LE0323-1CB23-4	71	0.03561						
11	160 M	IE3	1465	72	91.4	92.4	92.6	0.86	20	7.8	2.4	3.8	61	73	1LE0323-1DB23-4	95	0.06482						
15	160 L	IE3	1465	97.8	92.1	92.9	93.0	0.86	27.5	8.2	2.6	3.8	61	73	1LE0323-1DB43-4	112	0.08109						
18.5	180 M	IE3	1470	120	92.6	93.0	92.5	0.83	34.5	7.8	2.6	3.6	63	76	1LE0043-1EB23-4	162	0.1339						
22	180 L	IE3	1470	143	93.0	93.7	93.6	0.83	41	7.8	2.6	3.6	63	76	1LE0043-1EB43-4	178	0.1531						
30	200 L	IE3	1475	194	93.6	94.3	94.2	0.84	55	7.8	2.6	3.6	63	76	1LE0043-2AB43-4	234	0.245						
37	225 S	IE3	1482	238	93.9	94.1	93.4	0.85	67	8.3	3.0	3.6	65	78	1LE0043-2BB03-4	294	0.515						
45	225 M	IE3	1482	290	94.2	94.2	93.7	0.85	81	8.3	3.3	3.6	65	78	1LE0043-2BB23-4	322	0.548						
Voltages																Order code							
For other voltages and more information, see from page 2/6																...							
Types of construction										Version				Order code									
Without flange		IM B3								Standard				A									
For other types of construction and more information, see from page 2/7																-							
Motor protection										Version				Order code									
Without																Standard				A			
For other motor protection and more information, see from page 2/8																...							
Terminal box position										Version				Order code									
Terminal box at top																Standard				4			
Special versions																Order code							
For options, see from page 2/9																1LE0 ... -Z ...							

2



Aluminum series SIMOTICS FL 1LE0323 and cast-iron series SIMOTICS FL 1LE0043 – self-ventilated

Selection and ordering data

P _{rated} , 50 Hz/ P50	Frame size	IE class	Operating values at rated power										L _{pFA} , 50 Hz	L _{WA} , 50 Hz	Aluminum series 1LE0323 Cast-iron series 1LE0043 Article No.	m _{IM B3}	J
			η _{rated} 50 Hz	T _{rated} 50 Hz	η _{rated} 50 Hz, 4/4	η _{rated} 50 Hz, 3/4	η _{rated} 50 Hz, 2/4	cos φ _{rated} 50 Hz, 4/4	I _{rated} 50 Hz, 400 V	Start- ing current	Start- ing torque	Break down torque					
kW	FS		rpm	Nm	%	%	%		A							kg	kgm ²
<ul style="list-style-type: none"> • Cooling: Self-ventilated (IC 411) • Efficiency according to IEC 60034-30: IE3 Premium Efficiency • Insulation: Thermal class 155 (temperature class F), IP55 degree of protection, utilization in accordance with thermal class 130 (temperature class B) 																	
6-pole: 1000 rpm at 50 Hz, 230 VΔ / 400 VY																	
0.55	80 M	IE3	940	5.6	77.2	77.5	74.6	0.67	1.53	5.0	2.7	3.4	44	55	1LE0323-0DC32-2	15	0.00310
0.75	90 S	IE3	940	7.6	78.9	80.3	78.0	0.70	1.96	5.0	2.4	3.2	45	57	1LE0323-0EC02-2	19	0.00436
1.1	90 L	IE3	945	11.1	81.0	81.6	80.4	0.69	2.85	5.5	2.7	3.5	45	57	1LE0323-0EC42-2	22	0.00513
1.5	100 L	IE3	950	15.1	82.5	84.1	82.9	0.74	3.55	5.5	2.5	3.5	49	61	1LE0323-1AC42-2	33	0.01136
2.2	112 M	IE3	945	22.2	84.3	86.1	95.7	0.74	5.1	6.0	2.7	3.4	53	65	1LE0323-1BC22-2	39	0.01451
3	132 S	IE3	965	29.7	85.6	86.6	86.0	0.75	6.7	6.0	2.7	4.0	57	69	1LE0323-1CC02-2	54	0.02666
4	132 M	IE3	960	40	86.8	88.5	88.7	0.75	8.9	6.0	2.7	3.4	57	69	1LE0323-1CC22-2	63	0.03045
5.5	132 M	IE3	960	54.7	88.0	89.2	89.0	0.76	11.9	6.5	2.7	4.0	57	69	1LE0323-1CC32-2	71	0.04125
6-pole: 1000 rpm at 50 Hz, 400 VΔ / 690 VY																	
1.5	100 L	IE3	950	15.1	82.5	84.1	82.9	0.74	3.55	5.5	2.5	3.5	49	61	1LE0323-1AC43-4	33	0.01136
2.2	112 M	IE3	945	22.2	84.3	86.1	95.7	0.74	5.1	6.0	2.7	3.4	53	65	1LE0323-1BC23-4	39	0.01451
3	132 S	IE3	965	29.7	85.6	86.6	86.0	0.75	6.7	6.0	2.7	4.0	57	69	1LE0323-1CC03-4	54	0.02666
4	132 M	IE3	960	40	86.8	88.5	88.7	0.75	8.9	6.0	2.7	3.4	57	69	1LE0323-1CC23-4	63	0.03045
5.5	132 M	IE3	960	54.7	88.0	89.2	89.0	0.76	11.9	6.5	2.7	4.0	57	69	1LE0323-1CC33-4	71	0.04125
7.5	160 M	IE3	980	73.1	89.1	90.4	90.3	0.78	15.6	6.5	2.7	3.6	61	73	1LE0323-1DC23-4	95	0.07030
11	160 L	IE3	980	107	90.3	90.3	89.8	0.77	23	7.0	2.7	3.6	61	73	1LE0323-1DC43-4	120	0.07068
15	180 L	IE3	975	147	91.2	92.1	91.8	0.80	29.5	7.0	2.3	3.0	59	73	1LE0043-1EC43-4	163	0.2008
18.5	200 L	IE3	978	181	91.7	92.5	92.2	0.80	36.5	7.0	2.3	3.0	59	73	1LE0043-2AC43-4	212	0.312
22	200 L	IE3	980	214	92.2	93.1	93.0	0.80	43	7.0	2.6	3.0	59	73	1LE0043-2AC53-4	229	0.356
30	225 M	IE3	982	291	92.9	93.9	94.3	0.83	56	7.6	2.6	3.0	60	74	1LE0043-2BC23-4	321	0.740
Voltages																Order code	
For other voltages and more information, see from page 2/6																...	
Types of construction																Version	
Without flange IM B3																Standard	
For other types of construction and more information, see from page 2/7																A	
Motor protection																Version	
Without																Standard	
For other motor protection and more information, see from page 2/8																A	
Terminal box position																Version	
Terminal box at top																Standard	
4																-	
Special versions																Order code	
For options, see from page 2/9																1LE0 ... - -Z ...+...+...+	

Note:

All SIMOTICS FL 6-pole motors are intended for ordering with option code T98 Container delivery (see page 2/9).
When ordered from warehouse without option code T98, the typical warehouse delivery time is not achieved.



SIMOTICS FL standard motors

Article No. supplements and special versions · Voltages

Aluminum series SIMOTICS FL 1LE0323 and cast-iron series SIMOTICS FL 1LE0043

Selection and ordering data

Voltages	Article No. supplement Voltage code 12th and 13th position of the Article No.	Additional identification code with order code and plain text if required	Frame size									Motor version				
			80	90	100	112	132	160	180	200	225	IEC	IE3			
			1LE0323													
											1LE0043					
	1LE0 . . . - . . . - . . .	Order code														

Voltage at 50 Hz												
50 Hz 220 VΔ/380 VY ¹⁾	2	1	–	○	○	○	○	○	–	–	–	–
50 Hz 230 VΔ/400 VY	2	2	–	□	□	□	□	□	–	–	–	–
50 Hz 400 VΔ/690 VY	3	4	–	–	–	□	□	□	□	□	□	□
50 Hz 380 VΔ/660 VY ¹⁾	3	3	–	–	–	○	○	○	○	○	○	○
50 Hz 240 VΔ/415 VY ¹⁾	2	3	–	✓	✓	✓	✓	✓	–	–	–	–
50 Hz 415 VΔ ¹⁾	3	5	–	✓	✓	✓	✓	✓	✓	✓	✓	✓

- Standard version
- Without additional charge
- ✓ With additional charge
- Not possible





¹⁾ Intended for ordering with option code T98 Container delivery (see page 2/9). When ordered from warehouse without option code T98, the typical warehouse delivery time is not achieved.

SIMOTICS FL standard motors

Article No. supplements and special versions · Types of construction

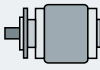
Aluminum series SIMOTICS FL 1LE0323 and cast-iron series SIMOTICS FL 1LE0043

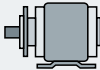
Selection and ordering data

Types of construction	Article No.	supplement	Frame size									Motor version		
			80	90	100	112	132	160	180	200	225	IEC	IE3	
	Type of construction code letter	For types of construction with order code(s)	1LE0323									IEC	IE3	
	14th position of the Article No.	Article No. with additional identification code -Z							1LE0043					
	1LE0...-.....-...(-Z)	Order code												
Without flange														
IM B3		A	-	□	□	□	□	□	□	□	□	□		
With flange		EN 50347 DIN 42948		FF165 A 200	FF165 A 200	FF215 A 250	FF215 A 250	FF265 A 300	FF300 A 350	FF300 A 350	FF350 A 400	FF400 A 450		
IM B5		F	-	✓	✓	✓	✓	✓	✓	✓	✓	✓		
IM V1 without protective cover		G	-	✓	✓	✓	✓	✓	✓	✓	✓	✓		
IM B35		J	-	✓	✓	✓	✓	✓	✓	✓	✓	✓		
With flange		EN 50347 DIN 42948		FT100 C 120	FT115 C 140	FT130 C 160	FT130 C 160	FT165 C 200	FT215 C 250	-	-	-		
IM B14		K	-	✓	✓	✓	✓	✓	✓					
IM B34		N	-	✓	✓	✓	✓	✓	✓	-	-	-		

- Standard version
- ✓ With additional charge
- Not possible

SIMOTICS FL standard motors

Article No. supplements and special versions · Motor protection · Terminal box position

Aluminum series SIMOTICS FL 1LE0323 and cast-iron series SIMOTICS FL 1LE0043

Selection and ordering data

Motor protection	Article No.	supplement	Frame size									Motor version		
			80	90	100	112	132	160	180	200	225	IEC	IE3	
		Additional identification code with order code and plain text if required	1LE0323						1LE0043			IEC	IE3	
	1LE0.....	Order code												

Motor protection												
Without (standard)	A	–	<input type="checkbox"/>	<input type="checkbox"/>	<input type="checkbox"/>	<input type="checkbox"/>	<input type="checkbox"/>	<input type="checkbox"/>	<input type="checkbox"/>	<input type="checkbox"/>	<input type="checkbox"/>	<input type="checkbox"/>
3 PTC thermistors – for tripping (2 terminals)	B	–	<input checked="" type="checkbox"/>	<input checked="" type="checkbox"/>	<input checked="" type="checkbox"/>	<input checked="" type="checkbox"/>	<input checked="" type="checkbox"/>	<input checked="" type="checkbox"/>	<input checked="" type="checkbox"/>	<input checked="" type="checkbox"/>	<input checked="" type="checkbox"/>	<input checked="" type="checkbox"/>

- Standard version
 With additional charge

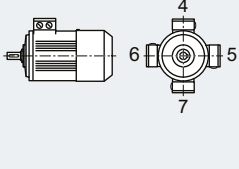
Terminal box position	Article No.	supplement	Frame size									Motor version		
			80	90	100	112	132	160	180	200	225	IEC	IE3	
		Additional identification code with order code and plain text if required	1LE0323						1LE0043			IEC	IE3	
	1LE0.....	Order code												

Terminal box position												
Terminal box top	4	–	<input type="checkbox"/>	<input type="checkbox"/>	<input type="checkbox"/>	<input type="checkbox"/>	<input type="checkbox"/>	<input type="checkbox"/>	<input type="checkbox"/>	<input type="checkbox"/>	<input type="checkbox"/>	<input type="checkbox"/>

- Standard version

Selection and ordering data

Special versions	Additional identification code -Z with order code and plain text if required	Frame size										Motor version		
		80	90	100	112	132	160	180	200	225	IEC	IE3		
		1LE0323												
								1LE0043						
1LE0 -Z		Order code												
Mechanical version and degrees of protection														
Condensation drainage holes ²⁾	H03	✓	✓	✓	✓	✓	✓	✓	✓	✓	✓			
Prepared for mountings, threaded hole only	G46	✓	✓	✓	✓	✓	✓	✓	✓	✓	✓			
Versions in accordance with standards and specifications														
CCC China Compulsory Certification ²⁾	D01	✓	✓	–	–	–	–	–	–	–	–	Only for: Voltage code 2-1 (12th and 13th position of the Article No.)		
China Energy Efficiency Label	D34	○	○	○	○	○	○	○	○	○	○			
TR CU product safety certificate EAC for Eurasian customs union	D47	✓	✓	✓	✓	✓	✓	✓	✓	✓	✓			
Bearings and lubrication														
Located bearing DE	L20	✓	✓	✓	✓	✓	✓	–	–	–				
Bearing design for increased cantilever forces	L22	–	–	✓	✓	✓	✓	✓	✓	✓				
Regreasing device ²⁾	L23	–	–	✓	✓	✓	✓	✓	✓	✓				
Heating and ventilation														
Anti-condensation heating for 230 V (2 terminals) ²⁾	Q02	✓	✓	✓	✓	✓	✓	✓	✓	✓				
Rating plate and additional rating plates														
Additional rating plate for voltage tolerance ¹⁾	B07	✓	✓	✓	✓	✓	✓	✓	✓	✓				
Packaging, safety notes, documentation and test certificates														
CE marking		□	□	□	□	□	□	□	□	□				
Sea-worthy packing for export		□	□	□	□	□	□	□	□	□	Only for: Combination with option code T98			
Acceptance test certificate 3.1 in accordance with EN 10204	B02	✓	✓	✓	✓	✓	✓	✓	✓	✓				
Without "Made in ..." on the rating plate	B13	○	○	○	○	○	○	○	○	○				
Container delivery instead of warehouse delivery	T98	○	○	○	○	○	○	○	○	○	Please contact Siemens sales for support with container order			

- Standard version
- Without additional charge
- ✓ With additional charge
- Not possible

¹⁾ Can be ordered only for 230 VΔ/400 VY or 400 VΔ/690 VY (voltage code "22" or "34")

²⁾ Intended for ordering with option code T98 Container delivery. When ordered from warehouse without option code T98, the typical warehouse delivery time is not achieved.

SIMOTICS FL standard motors

Dimensions · Aluminum series SIMOTICS FL

IE3, Premium Efficiency – self-ventilated · Frame sizes 80 M to 160 L

Dimensional drawings

Type of construction IM B3

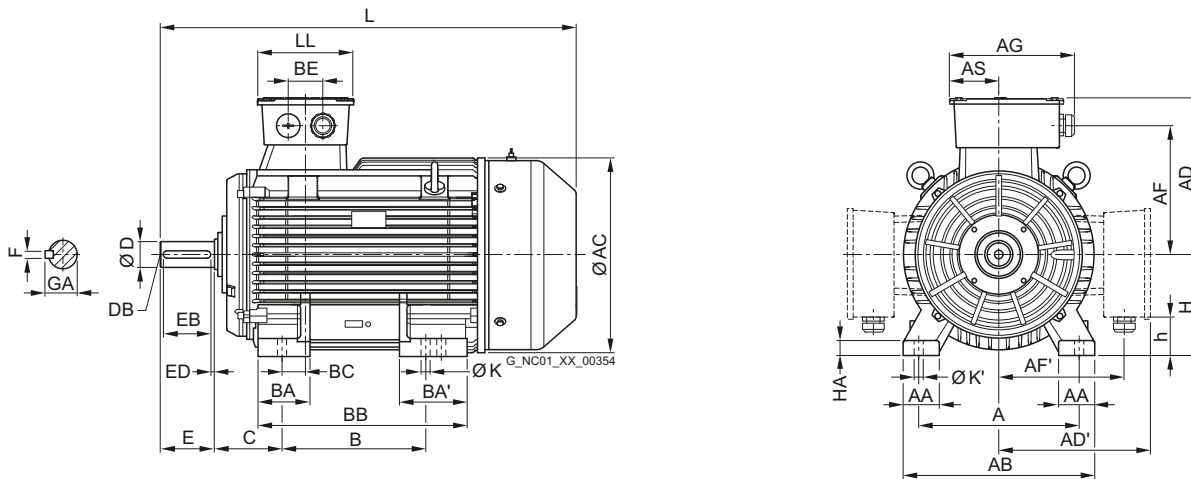

Types of construction IM B5 and IM V1

For flange dimensions, see page 2/14 (Z = the number of retaining holes)

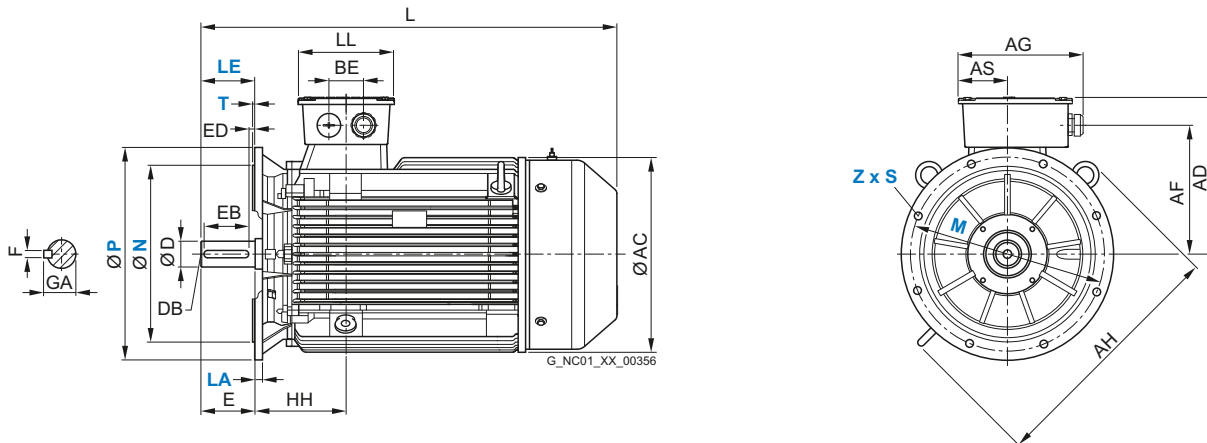

For motor		Dimension designation acc. to IEC																			
Frame size	Motor type	No. of poles	A	AA	AB	AC ¹⁾	AD	AD'	AF	AF'	AG	AS	B ²⁾	BA	BA'	BB	BC	BE	C	H	HA
80 M	0D.2. 0D.3	2, 4, 6	125	36	165	165	150	150	110.5	110.5	141	65.5	100	32	32	135	26	42	50	80	10
90 S	0E.0	2, 4, 6	140	36	180	185	160	160	120.5	120.5	141	65.5	100	37	37	140	25	42	56	90	10
90 L	0E.4												125			165					
100 L	1A.4 1A.5	2, 4, 6 4	160	40	205	200	185	185	142	142	160	69	140	58	58	176	30.5	54	63	100	12
112 M	1B.2	2, 4, 6	190	45	230	223	193	193	154	154	160	69	140	38.5	38.5	180	22	54	70	112	15.5
132 S	1C.0 1C.1	2, 4, 6 2	216	50	260	265	223	223	177	177	160	69	140	42	42	186	32.5	54	89	132	15
132 M	1C.2 1C.3	4, 6 6											178			224			89		
160 M	1D.2 1D.3	2, 4, 6 2	254	60	320	315	255	255	208	208	209	82	210	47	47	258	49	56	108	160	20
160 L	1D.4	2, 4, 6											254			302			108		

¹⁾ Measured across the bolt heads.

²⁾ This dimension is assigned in DIN EN 50347 to the frame size listed.

SIMOTICS FL standard motors

Dimensions · Aluminum series SIMOTICS FL

IE3, Premium Efficiency – self-ventilated · Frame sizes 80 M to 160 L

Dimensional drawings

Type of construction IM B35

For flange dimensions, see page 2/14 (Z = the number of retaining holes)

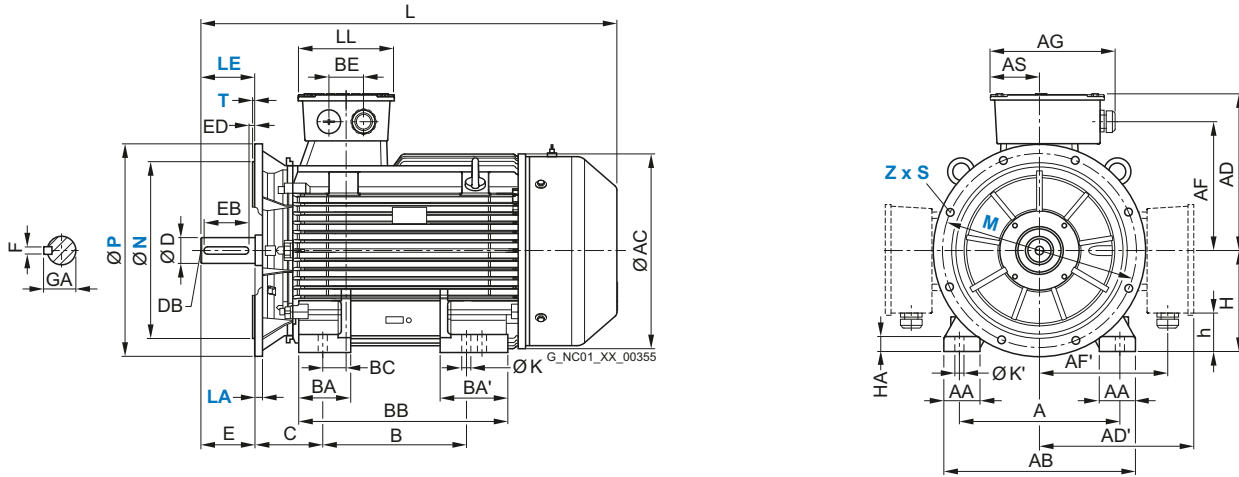

Type of construction IM B14

For flange dimensions, see page 2/14 (Z = the number of retaining holes)

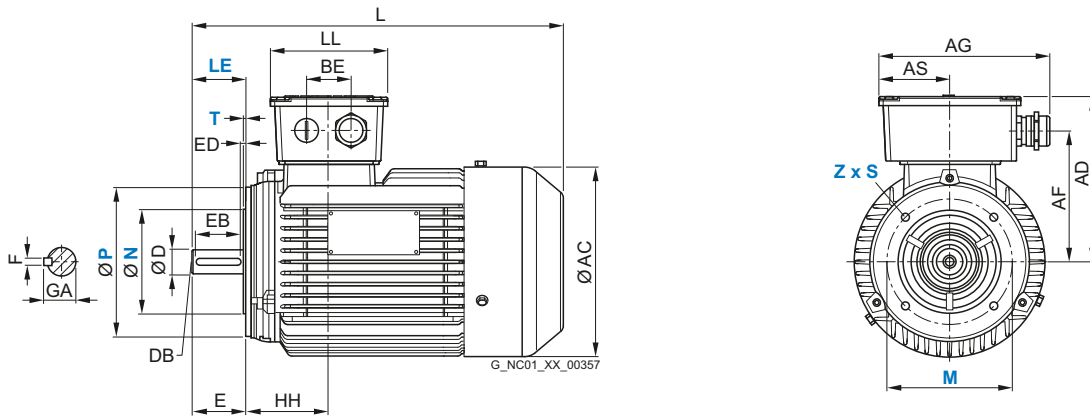

For motor	Motor type	No. of poles	Dimension designation acc. to IEC						DE shaft extension						
			HH	K	K'	L	LC	LL	D	DB	E	EB	ED	F	GA
80 M	OD.2. OD.3	2, 4, 6	76	10	14	335	363	109	19	M6	40	32	3.5	6	21.5
90 S	0E.0	2, 4, 6	76	10	14	370	411	109	24	M8	50	40	3.5	8	27
90 L	0E.4					395	436								
100 L	1A.4 1A.5	2, 4, 6 4	93.5	12	16	465	516.5	116	28	M10	60	50	4	8	31
112 M	1B.2	2, 4, 6	92	12	16	455	504.5	116	28	M10	60	50	4	8	31
132 S	1C.0 1C.1	2, 4, 6 2	121.5	12	16	515	582	116	38	M12	80	70	4	10	41
132 M	1C.2 1C.3	4, 6 6				560	627								
160 M	1D.2 1D.3	2, 4, 6 2	157	15	19	620	701	164	42	M16	110	100	5	12	45
160 L	1D.4	2, 4, 6				680	761								

SIMOTICS FL standard motors

Dimensions · Cast-iron series SIMOTICS FL

IE3, Premium Efficiency – self-ventilated · Frame sizes 180 M to 225 M

Dimensional drawings

Type of construction IM B3

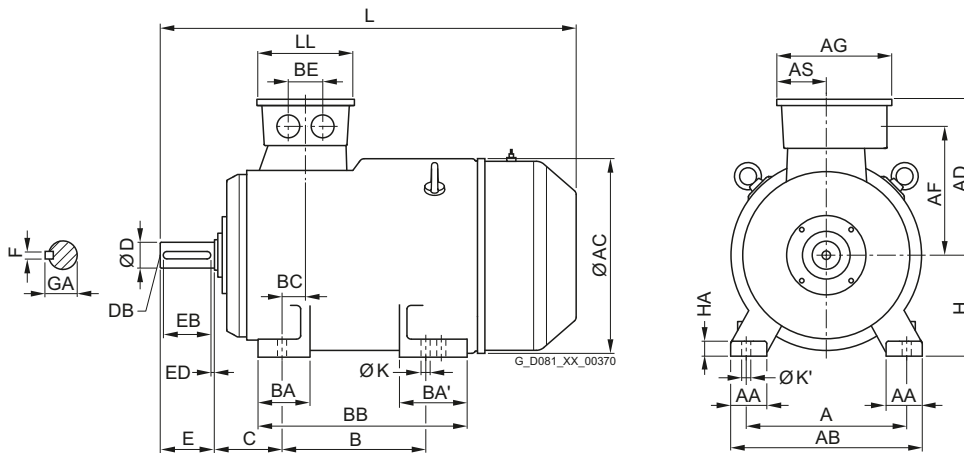

Types of construction IM B5 and IM V1

For flange dimensions, see page 2/14 (Z = the number of retaining holes)

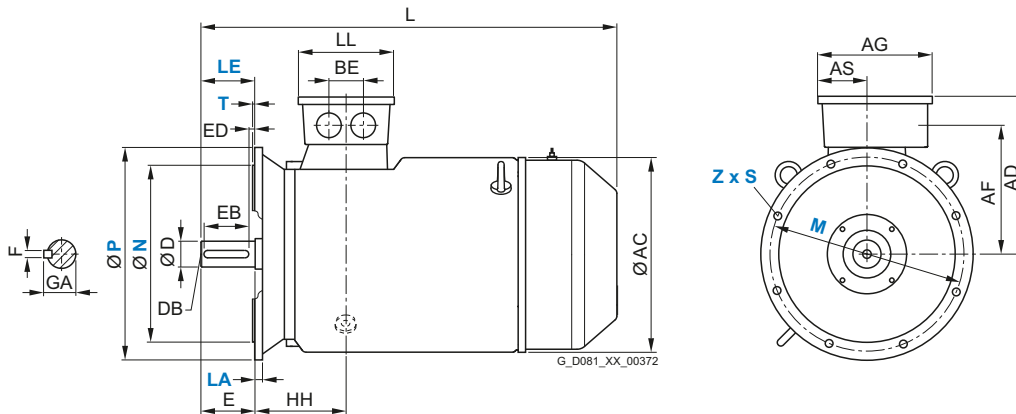

For motor			Dimension designation acc. to IEC																
Frame size	Motor type	No. of poles	A	AA	AB	AC ¹⁾	AD	AF	AG	AS	B ²⁾	BA	BA'	BB	BC	BE	C	H	HA
180 M	1E.2	2, 4, 6	279	65	339	368	275	223	231	94	241	80	80	301	30	68	121	180	22
180 L	1E.4	4, 6									279			339			121		
200 L	2A.4 2A.5	2, 6 2, 4, 6	318	70	378	410	305	250	288	108	305	80	80	369	32	85	133	200	25
225 S	2B.0	4	356	80	436	449	330	278	288	108	286	90	90	348	31	85	149	225	34
225 M	2B.2	2 4, 6									311			373			149		

¹⁾ Measured across the bolt heads.

²⁾ This dimension is assigned in DIN EN 50347 to the frame size listed.

SIMOTICS FL standard motors

Dimensions · Cast-iron series SIMOTICS FL

IE3, Premium Efficiency – self-ventilated · Frame sizes 180 M to 225 M

Dimensional drawings

Type of construction IM B35

For flange dimensions, see page 2/14 (Z = the number of retaining holes)

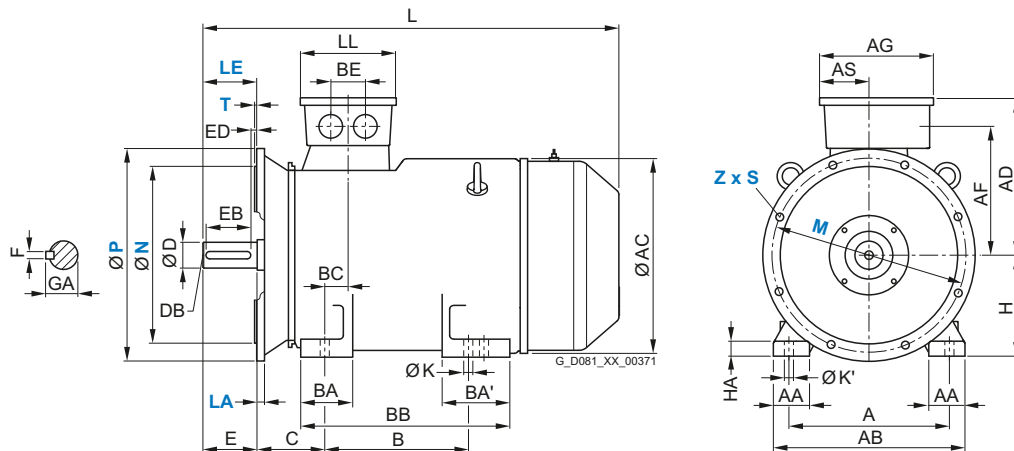

For motor			Dimension designation acc. to IEC					DE shaft extension							
Frame size	Motor type	No. of poles	HH	K	K'	L	LC	LL	D	DB	E	EB	ED	F	GA
180 M	1E.2	2, 4, 6	158	15	15	695	836	158	48	M16	110	100	5	14	51.5
180 L	1E.4	4, 6				725	876								
200 L	2A.4 2A.5	2, 6 2, 4, 6	203	19	19	790	927	215	55	M20	110	100	5	16	59
225 S	2B.0	4	212	19	19	825	965	215	60	M20	140	125	10	18	64
225 M	2B.2	2 4, 6				850 880	940 995		55 60		110 140	100 125	5 10	16 18	59 64

SIMOTICS FL standard motors

Dimensions · Aluminum series SIMOTICS FL and cast-iron series SIMOTICS FL

Flange dimensions

Dimensional drawings

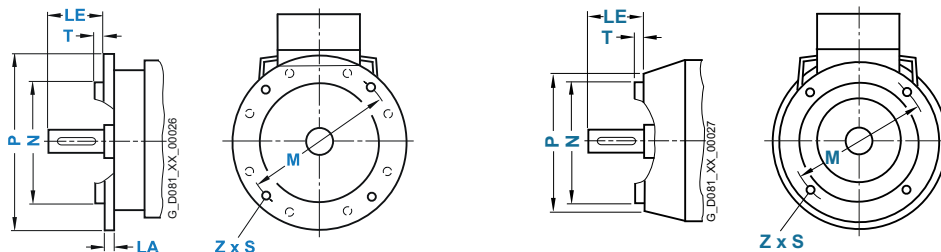

Frame size	Type of construction	Flange type	Flange with through holes (FF/A) Flange with tapped holes (FT/C)		Dimension designation acc. to IEC							
			Acc. to EN 50347	Acc. to DIN 42948	LA ¹⁾	LE	M	N	P	S	T	Z
80	IM B5, IM B35, IM V1	Flange	FF165	A 200	10	40	165	130	200	12	3,5	4
	IM B14, IM B34	Flange	FT100	C 120	–	40	100	80	120	M6	3	4
90	IM B5, IM B35, IM V1	Flange	FF165	A 200	10	50	165	130	200	12	3,5	4
	IM B14, IM B34	Flange	FT115	C 140	–	50	115	95	140	M8	3	4
100	IM B5, IM B35, IM V1	Flange	FF215	A 250	11	60	215	180	250	14,5	4	4
	IM B14, IM B34	Flange	FT130	C 160	–	60	130	110	160	M8	3,5	4
112	IM B5, IM B35, IM V1	Flange	FF215	A 250	11	60	215	180	250	14,5	4	4
	IM B14, IM B34	Flange	FT130	C 160	–	60	130	110	160	M8	3,5	4
132	IM B5, IM B35, IM V1	Flange	FF265	A 300	13	80	265	230	300	14,5	4	4
	IM B14, IM B34	Flange	FT165	C 200	–	80	165	130	200	M10	3,5	4
160	IM B5, IM B35, IM V1	Flange	FF300	A 350	14	110	300	250	350	18,5	5	4
	IM B14, IM B34	Flange	FT215	C 250	–	110	215	180	250	M12	4	4
180	IM B5, IM B35, IM V1	Flange	FF300	A 350	13	110	300	250	350	18,5	5	4
200	IM B5, IM B35, IM V1	Flange	FF350	A 400	15	110	350	300	400	18,5	5	4
225	IM B5, IM B35, IM V1	Flange	FF400	A 450	16	110/140 ²⁾	400	350	450	18,5	5	8

¹⁾ Flange LA size refer to the thickness at the flange mounting hole.

²⁾ Dimension 140 valid for 4- and 6-pole motors.

Selection and ordering at Siemens Industry Mall, downloading and ordering catalogs

Easy product selection and ordering:

Easy Selection SIMOTICS LV motors and Industry Mall

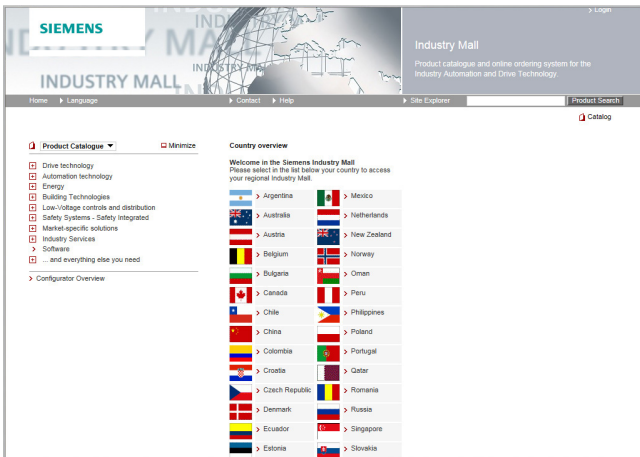

Easy Selection SIMOTICS LV motors

The Easy Selection is a simple but powerful tool how to select a SIMOTICS low voltage motor by inserting the basic parameters and optional filters. The tool is completely online and supports also mobile devices.

SIMOTICS FL is shown as the first option, when it fulfills the requirements. It is possible to generate standard documentation package directly from the tool, as well as insert the SIMOTICS FL motor to the shopping cart of Industry Mall.

www.siemens.com/lv-easy

Industry Mall

The Industry Mall is a Siemens AG Internet ordering platform. It provides you with online access to a comprehensive product spectrum that is presented in an informative, well-organized way.

Powerful search functions help you select the required products, while configurators enable you to configure complex product and system components quickly and easily. CAx data are also available for you to use.

Data transfer allows the entire procedure, from selection through ordering to tracking and tracing, to be carried out online. Availability checks, individual customer discounting, and quotation preparation are also possible.

www.siemens.com/industrymall

Downloading catalogs

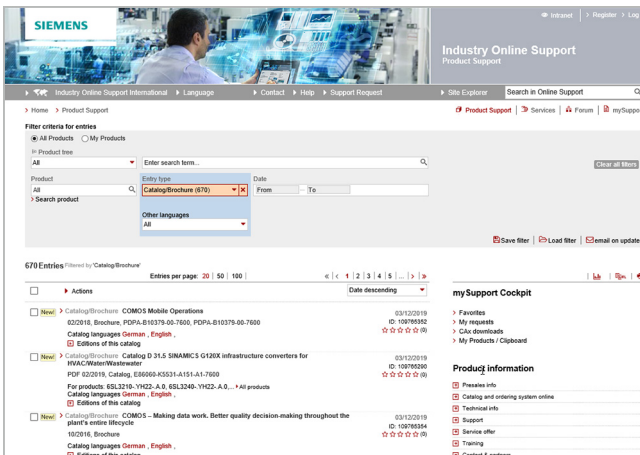

Siemens Industry Online Support

You can download catalogs and brochures in PDF format from Siemens Industry Online Support without having to register.

The filter box makes it possible to perform targeted searches.

www.siemens.com/industry-catalogs

Ordering printed catalogs



Please contact your local Siemens branch if you are interested in ordering printed catalogs.

Addresses can be found at

www.siemens.com/automation-contact

Get more information

Siemens Motors:
www.siemens.com/motors

Local partners worldwide:
www.siemens.com/automation-contact

Published by
Siemens AG

Digital Industries
Motion Control
Postfach 31 80
91050 Erlangen, Germany

PDF (Article No. E86060-L5581-A601-A2-7600)
V7.MKKATA.LVM.300
KG 1222 42 En
Produced in Germany
© Siemens 2022

Subject to changes and errors. The information given in this document only contains general descriptions and/or performance features which may not always specifically reflect those described, or which may undergo modification in the course of further development of the products. The requested performance features are binding only when they are expressly agreed upon in the concluded contract.

All product designations may be trademarks or product names of Siemens AG or other companies whose use by third parties for their own purposes could violate the rights of the owners.

Security information

Siemens provides products and solutions with industrial security functions that support the secure operation of plants, systems, machines and networks.

In order to protect plants, systems, machines and networks against cyber threats, it is necessary to implement – and continuously maintain – a holistic, state-of-the-art industrial security concept. Siemens' products and solutions constitute one element of such a concept.

Customers are responsible for preventing unauthorized access to their plants, systems, machines and networks. Such systems, machines and components should only be connected to an enterprise network or the internet if and to the extent such a connection is necessary and only when appropriate security measures (e.g. firewalls and/or network segmentation) are in place.

For additional information on industrial security measures that may be implemented, please visit
<https://www.siemens.com/industrialsecurity>

Siemens' products and solutions undergo continuous development to make them more secure. Siemens strongly recommends that product updates are applied as soon as they are available and that the latest product versions are used. Use of product versions that are no longer supported, and failure to apply the latest updates may increase customer's exposure to cyber threats.

To stay informed about product updates, subscribe to the Siemens Industrial Security RSS Feed under
<https://www.siemens.com/cert>

For more information please contact your distributor:

Please scan the
QR code for more
information on
Siemens Motors.

